



MULHERN+KULP
RESIDENTIAL STRUCTURAL ENGINEERING

300 Brookside Avenue, Building 4, Ambler, PA 19002 ▶ p 215-646-8001 ▶ mulhernkulp.com

CALCULATION PACKAGE

January 21, 2019

J Designs

3440 97th Ave

Mercer Island
Washington

MULHERN & KULP STRUCTURAL ENGINEERING, INC.

Prepared By:

Nicholas J. Dastalfo *Staff Engineer*

Nicholas J. Martignetti, P.E., S.E. *Project Manager*

James G. Friling, P.E. Principal & Director of Operations

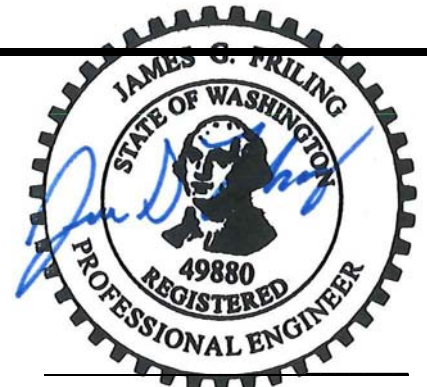

Signature, Seal & Date



BEAM & HEADER CALCULATIONS

BEAM DESCRIPTION: TYP. EXT. HDR - WORST CASE LOAD B1

PARAMETERS:

L = FT

W = KLF

P = K

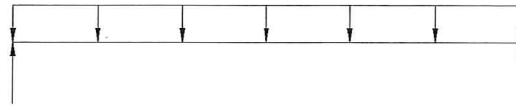

ANALYSIS:

R_{MAX} = K

V_D = K

< V_{ALL} = K

ADEQUATE

M_{MAX} = K-FT

< M_{ALL} = K-FT

ADEQUATE

Δ_{TL} = IN.

L/ < L/240

ADEQUATE

4 x 10

BEAM DESCRIPTION: TYP. EXT. HDR - WORST CASE SPAN B1

PARAMETERS:

L = FT

W = KLF

P = K

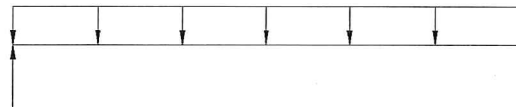

ANALYSIS:

R_{MAX} = K

V_D = K

< V_{ALL} = K

ADEQUATE

M_{MAX} = K-FT

< M_{ALL} = K-FT

ADEQUATE

Δ_{TL} = IN.

L/ < L/240

ADEQUATE

4 x 10

BEAM DESCRIPTION: ROOF FRNG - FLUSH BM. @ MAST. BD. / LAUNDRY (2SPAN) B2

PARAMETERS:

L = FT

W = KLF

P = K

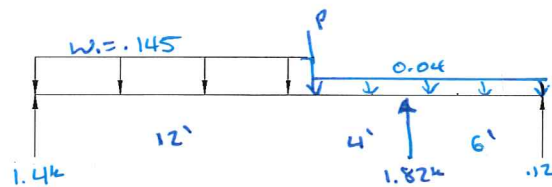

ANALYSIS:

R_{MAX} = K

V_D = K

< V_{ALL} = K

ADEQUATE

M_{MAX} = K-FT

< M_{ALL} = K-FT

ADEQUATE

Δ_{TL} = IN.

L/ < L/240

ADEQUATE

3 1/2" x 11 7/8" LVL

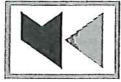

BEAM & HEADER CALCULATIONS

BEAM DESCRIPTION: ROOF FRMG - 2 SPAN FLUSH BM @ MAST BD / STAIRS 133

PARAMETERS:

L = FT

W = KLF

P = K

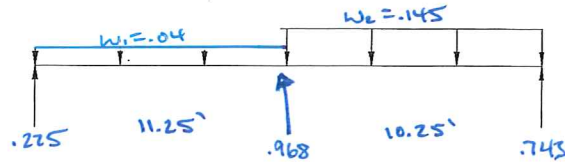

ANALYSIS:

$R_{MAX} =$ K $V_D =$ K $< V_{ALL} =$ K ADEQUATE

$M_{MAX} =$ K-FT $< M_{ALL} =$ K-FT ADEQUATE

$\Delta_{TL} =$ IN. $L/$ $< L/240$ ADEQUATE

1 3/4" x 11 7/8" LVL

BEAM DESCRIPTION: ROOF FRMG - INT. HDR @ MAST BD STAIRS 134

PARAMETERS:

L = FT

W = KLF

P = K

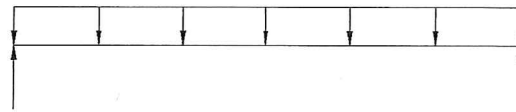

ANALYSIS:

$R_{MAX} =$ K $V_D =$ K $< V_{ALL} =$ K ADEQUATE

$M_{MAX} =$ K-FT $< M_{ALL} =$ K-FT ADEQUATE

$\Delta_{TL} =$ IN. $L/$ $< L/240$ ADEQUATE

4 x 10

BEAM DESCRIPTION: ROOF FRMG - FLUSH BM @ STAIR ROOF 135

PARAMETERS:

L = FT

W = KLF

P = K

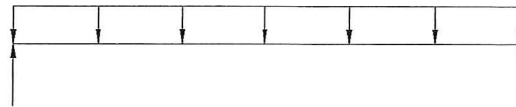

ANALYSIS:

$R_{MAX} =$ K $V_D =$ K $< V_{ALL} =$ K ADEQUATE

$M_{MAX} =$ K-FT $< M_{ALL} =$ K-FT ADEQUATE

$\Delta_{TL} =$ IN. $L/$ $< L/240$ ADEQUATE

3 1/2" x 11 7/8" LVL

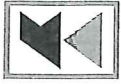

BEAM & HEADER CALCULATIONS

BEAM DESCRIPTION: ROOF FRMG - CANT'D FLUSH BM & LAUNDRY/STAIRS

136

PARAMETERS:

L = FT

W = KLF

P = K

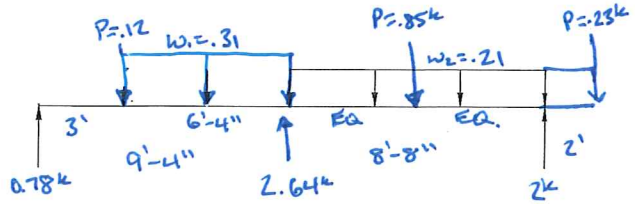

ANALYSIS:

$R_{MAX} = 2.64$ K

$V_D = -$ K

$V_{ALL} = 3.95$ K

ADEQUATE

$M_{MAX} = 4.2$ K-FT

$M_{ALL} = 8.925$ K-FT

ADEQUATE

$\Delta_{TL} = .116$ IN.

L/ < L/240

ADEQUATE

BEAM DESCRIPTION: ROOF FRMG - REAR MUST B'D WINDOW HDR (WORST CASE)

137

PARAMETERS:

L = FT

W = KLF

P = K

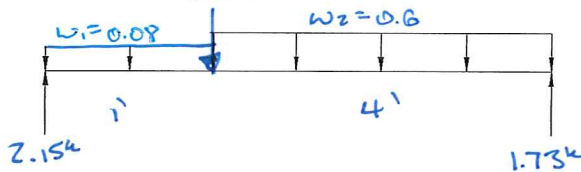

ANALYSIS:

$R_{MAX} = 2.15$ K

$V_D = -$ K

$V_{ALL} = 3.89$ K

ADEQUATE

$M_{MAX} = 2.49$ K-FT

$M_{ALL} = 4.12$ K-FT

ADEQUATE

$\Delta_{TL} = 0.03$ IN.

L/ < L/240

ADEQUATE

BEAM DESCRIPTION: 2ND FLZ FRMG - GARAGE DOOR HDR

138

PARAMETERS:

L = FT

W = KLF

P = K

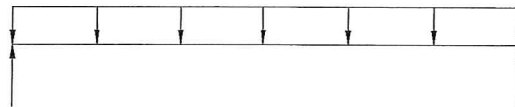

ANALYSIS:

$R_{MAX} = 3.52$ K

$V_D = -$ K

$V_{ALL} = 13.41$ K

ADEQUATE

$M_{MAX} = 14.08$ K-FT

$M_{ALL} = 30.36$ K-FT

ADEQUATE

$\Delta_{TL} = \frac{360.5}{I} 0.455$ IN.

L/ < L/240

ADEQUATE

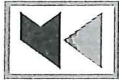

BEAM & HEADER CALCULATIONS

BEAM DESCRIPTION: 2nd FLR FRMG - FLUSH BM e GARAGE

139

350
45
350

PARAMETERS:

L = FT

W = KLF

P = K

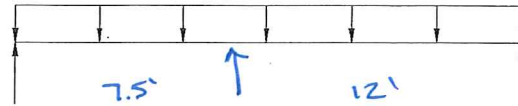

ANALYSIS:

R_{MAX} = K

V_D = K

< V_{ALL} = K

ADEQUATE

M_{MAX} = K-FT

< M_{ALL} = K-FT

ADEQUATE

Δ_{TL} = IN.

L/ < L/240

ADEQUATE

BEAM DESCRIPTION: 2nd FLR FRMG - HDR e INT. JRG WALL e GARAGE

1310

PARAMETERS:

L = FT

W = KLF

P = K

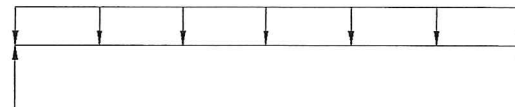

ANALYSIS:

R_{MAX} = K

V_D = K

< V_{ALL} = K

ADEQUATE

M_{MAX} = K-FT

< M_{ALL} = K-FT

ADEQUATE

Δ_{TL} = IN.

L/ < L/240

ADEQUATE

BEAM DESCRIPTION: 2nd FLR FRMG - FLUSH BM e KITCHEN / DINING

1311

PARAMETERS:

L = FT

W = KLF

P = K

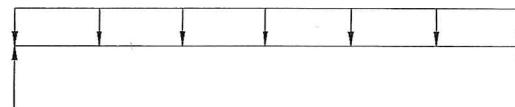

ANALYSIS:

R_{MAX} = K

V_D = K

< V_{ALL} = K

ADEQUATE

M_{MAX} = K-FT

< M_{ALL} = K-FT

ADEQUATE

Δ_{TL} = $\frac{60.8}{I}$ IN.

L/ < L/240

ADEQUATE

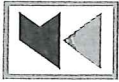

BEAM & HEADER CALCULATIONS

BEAM DESCRIPTION: 2nd FLR FRMG - DINING RM. REAR DOOR HDR

B12

PARAMETERS:

L = 8 FT

W = 0.97 KLF

P = - K

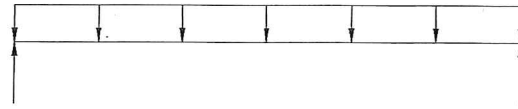

ANALYSIS:

R_{MAX} = 3.88 K

V_D = - K

< V_{ALL} = 7.9 K

ADEQUATE

M_{MAX} = 7.76 K-FT

< M_{ALL} = 17.85 K-FT

ADEQUATE

Δ_{TL} = 0.092 IN.

L/1000+ < L/240

ADEQUATE

3 1/2" x 11 7/8" LVL

485
465
480

BEAM DESCRIPTION: 2nd FLR FRMG - COV. PATIO BM e REAR

B13

PARAMETERS:

L = 14.5 FT

W = 0.22 KLF

P = - K

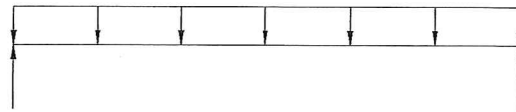

ANALYSIS:

R_{MAX} = 1.6 K

V_D = - K

< V_{ALL} = 7.21 K

ADEQUATE

M_{MAX} = 5.78 K-FT

< M_{ALL} = 6.94 K-FT

ADEQUATE

Δ_{TL} = 0.428 IN.

L/406 < L/240

ADEQUATE

6 x 10

BEAM DESCRIPTION: 2nd FLR FRMG - COV. PATIO BM. e SIDE

B14

PARAMETERS:

L = 10.5 FT

W = 0.1 KLF

P = - K

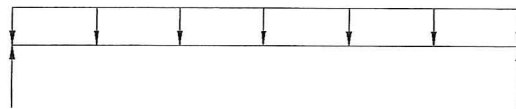

ANALYSIS:

R_{MAX} = 0.525 K

V_D = - K

< V_{ALL} = 7.21 K

ADEQUATE

M_{MAX} = 1.38 K-FT

< M_{ALL} = 6.94 K-FT

ADEQUATE

Δ_{TL} = 0.05 IN.

L/1000+ < L/240

ADEQUATE

6 x 10

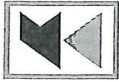

BEAM & HEADER CALCULATIONS

BEAM DESCRIPTION: 2nd FLR FRMB - FLUSH BM @ LIVING RM.

B15

PARAMETERS:

L = 23.5 FT

W = KLF

P = K

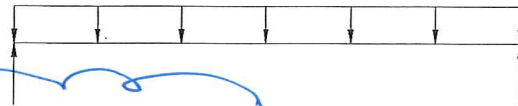

ANALYSIS:

$R_{MAX} =$ K $V_D =$ K $< V_{ALL} =$ K

ADEQUATE

$M_{MAX} =$ K-FT $< M_{ALL} =$ K-FT

ADEQUATE

$\Delta_{TL} =$ IN. $L/$ $< L/240$

ADEQUATE

W10 x 77

BEAM DESCRIPTION: 2nd FLR FRMB - FLUSH BM @ STAIRS

B16

PARAMETERS:

L = 8.5 FT

W = SHOWN KLF

P = 2.4 K

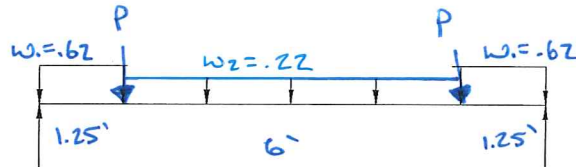

ANALYSIS:

$R_{MAX} = 3.84$ K $V_D = -$ K $< V_{ALL} = 3.95$ K

ADEQUATE

$M_{MAX} = 5.3$ K-FT $< M_{ALL} = 8.925$ K-FT

ADEQUATE

$\Delta_{TL} = 0.14$ IN. $L/$ 728 $< L/240$

ADEQUATE

1 3/4" x 11 7/8" LVL

BEAM DESCRIPTION: 2nd FLR FRMB - FLUSH BM @ OPEN TO ABOVE

B17

PARAMETERS:

L = 9 FT

W = SHOWN KLF

P = 0.06 K

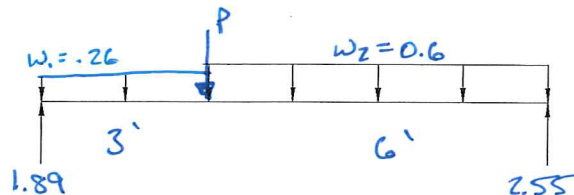

ANALYSIS:

$R_{MAX} = 2.55$ K $V_D = -$ K $< V_{ALL} = 3.95$ K

ADEQUATE

$M_{MAX} = 5.42$ K-FT $< M_{ALL} = 8.925$ K-FT

ADEQUATE

$\Delta_{TL} = 0.162$ IN. $L/$ 666 $< L/240$

ADEQUATE

1 3/4" x 11 7/8" LVL

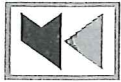

BEAM & HEADER CALCULATIONS

BEAM DESCRIPTION: 2nd FLR FRMG - CANT'D FLUSH BM BY STAIRS

B18

PARAMETERS:

L = FT
W = KLF
P = K

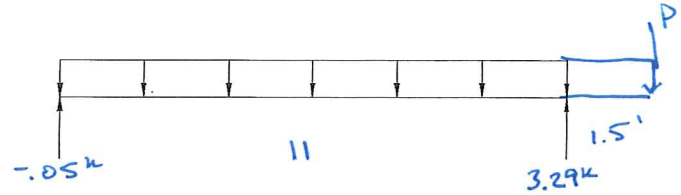

ANALYSIS:

$R_{MAX} =$ K $V_D =$ K $< V_{ALL} =$ K ADEQUATE
 $M_{MAX} =$ K-FT $< M_{ALL} =$ K-FT ADEQUATE
 $\Delta_{TL} =$ IN. $L/$ $< L/240$ ADEQUATE

BEAM DESCRIPTION: 2nd FLR FRMG - HDIZ & INT. GUEST RM. BRG. WALL

B19

PARAMETERS:

L = FT
W = KLF
P = K

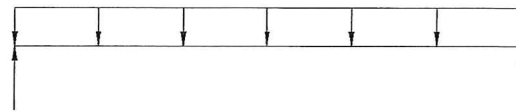

ANALYSIS:

$R_{MAX} =$ K $V_D =$ K $< V_{ALL} =$ K ADEQUATE
 $M_{MAX} =$ K-FT $< M_{ALL} =$ K-FT ADEQUATE
 $\Delta_{TL} =$ IN. $L/$ $< L/240$ ADEQUATE

BEAM DESCRIPTION: 2nd FLR FRMG - FLUSH BM @ LOW ROOF (WORST CASE)

B20

PARAMETERS:

L = FT
W = KLF
P = K

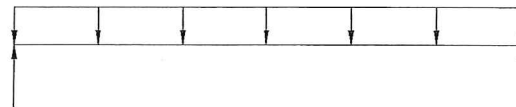

ANALYSIS:

$R_{MAX} =$ K $V_D =$ K $< V_{ALL} =$ K ADEQUATE
 $M_{MAX} =$ K-FT $< M_{ALL} =$ K-FT ADEQUATE
 $\Delta_{TL} =$ IN. $L/$ $< L/240$ ADEQUATE

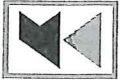

BEAM & HEADER CALCULATIONS

BEAM DESCRIPTION: 2nd FLR FRMG - LANT FLUSH RM & ENTRY ROOF B21

PARAMETERS:

L = FT
W = KLF
P = K

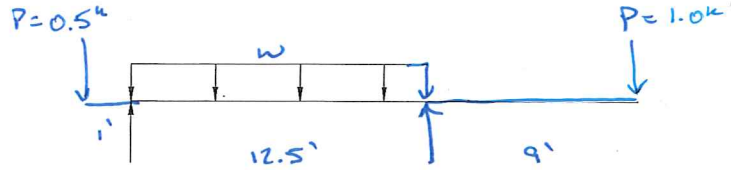

ANALYSIS:

$R_{MAX} =$ K $V_D =$ K $< V_{ALL} =$ K ADEQUATE
 $M_{MAX} =$ K-FT $< M_{ALL} =$ K-FT ADEQUATE
 $\Delta_{TL} =$ IN. $L/$ $< L/240$ ADEQUATE

C12 x 25

BEAM DESCRIPTION: 2nd FLR FRMG - GARAGE SIDE WINDOW HDR B22

PARAMETERS:

L = FT
W = KLF
P = K

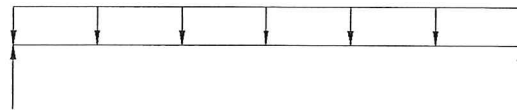

ANALYSIS:

$R_{MAX} =$ K $V_D =$ K $< V_{ALL} =$ K ADEQUATE
 $M_{MAX} =$ K-FT $< M_{ALL} =$ K-FT ADEQUATE
 $\Delta_{TL} =$ IN. $L/$ $< L/240$ ADEQUATE

4 x 8

BEAM DESCRIPTION: 1ST FLR FRMG - FLUSH RM & REC RM. B23

PARAMETERS:

L = FT
W = KLF
P = K

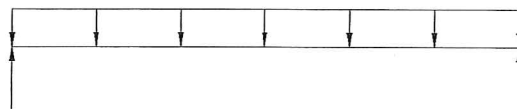

ANALYSIS:

$R_{MAX} =$ K $V_D =$ K $< V_{ALL} =$ K ADEQUATE
 $M_{MAX} =$ K-FT $< M_{ALL} =$ K-FT ADEQUATE
 $\Delta_{TL} = \frac{126.4}{I}$ IN. $L/$ $< L/240$ ADEQUATE

W10 x 45

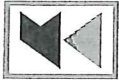

BEAM & HEADER CALCULATIONS

BEAM DESCRIPTION: 1ST FLR FRMG - CRAWL BM

B24

PARAMETERS:

L = 6.67 FT
W = .72 KLF
P = - K

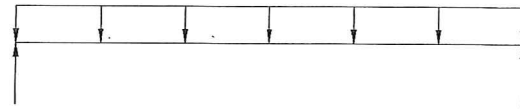

ANALYSIS:

$R_{MAX} = 2.4$ K $V_D = -$ K $< V_{ALL} = 3.89$ K ADEQUATE
 $M_{MAX} = 4.0$ K-FT $< M_{ALL} = 4.12$ K-FT ADEQUATE
 $\Delta_{TL} = 0.087$ IN. $L/923 < L/240$ ADEQUATE

4 x 10

BEAM DESCRIPTION: 1ST FLR FRMG - FURSH BM @ STAIRS

B25

PARAMETERS:

L = 8.5 FT
W = .28 KLF
P = - K

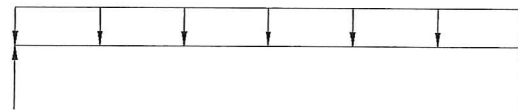

ANALYSIS:

$R_{MAX} = 1.19$ K $V_D = -$ K $< V_{ALL} = 3.95$ K ADEQUATE
 $M_{MAX} = 2.53$ K-FT $< M_{ALL} = 8.93$ K-FT ADEQUATE
 $\Delta_{TL} = 0.067$ IN. $L/10007 < L/240$ ADEQUATE

1 3/4" x 11 7/8" LVL

BEAM DESCRIPTION: 1ST FLR FRMG - DECK BM.

B26

PARAMETERS:

L = 14.5 FT w/ 4' CANT.
W = 0.375 KLF
P = - K

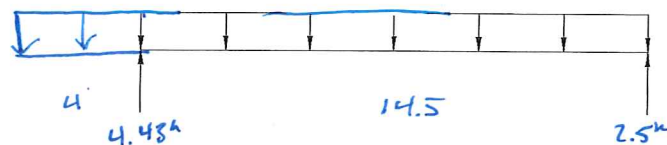

ANALYSIS:

$R_{MAX} = 4.48$ K $V_D = -$ K $< V_{ALL} = 10.2$ K ADEQUATE
 $M_{MAX} = 10.3$ K-FT $< M_{ALL} = 30.21$ K-FT ADEQUATE
 $\Delta_{TL} = 0.425$ IN. $L/419 < L/240$ ADEQUATE

5 1/2" x 10 1/2" GLB

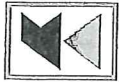

BEAM & HEADER CALCULATIONS

BEAM DESCRIPTION: 1ST FLR FRMG - HD/R e INT. BRG. WALL

B27

PARAMETERS:

L = FT
W = KLF
P = K

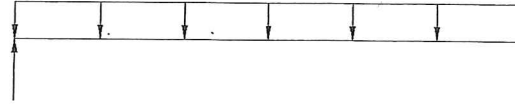

ANALYSIS:

$R_{MAX} =$ K $V_D =$ K $< V_{ALL} =$ K ADEQUATE
 $M_{MAX} =$ K-FT $< M_{ALL} =$ K-FT ADEQUATE
 $\Delta_{TL} =$ IN. $L/$ $< L/240$ ADEQUATE

BEAM DESCRIPTION: 1ST FLR FRMG - FLUSH BM e STORAGE/UTILITY w/ SWA

B28

PARAMETERS:

L = FT
W = KLF
P = K

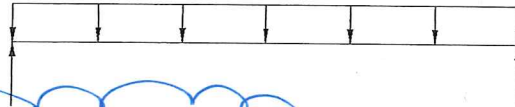

SEE OVERSTRENGTH CALCS

ANALYSIS:

$R_{MAX} =$ K $V_D =$ K $< V_{ALL} =$ K ADEQUATE
 $M_{MAX} =$ K-FT $< M_{ALL} =$ K-FT ADEQUATE
 $\Delta_{TL} =$ IN. $L/$ $< L/240$ ADEQUATE

BEAM DESCRIPTION: 1ST FLR FRMG - SIDE DECK BM.

B29

PARAMETERS:

L = FT
W = KLF
P = K

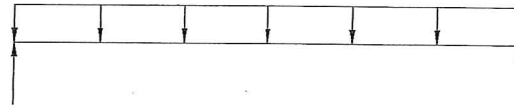

ANALYSIS:

$R_{MAX} =$ K $V_D =$ K $< V_{ALL} =$ K ADEQUATE
 $M_{MAX} =$ K-FT $< M_{ALL} =$ K-FT ADEQUATE
 $\Delta_{TL} =$ IN. $L/$ $< L/240$ ADEQUATE

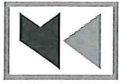

BEAM & HEADER CALCULATIONS

BEAM DESCRIPTION: 2nd FLR FRMG - FLUSH BH e LOW ROOF BY GUEST RM. B3D

PARAMETERS:

L = FT

W = KLF

P = K

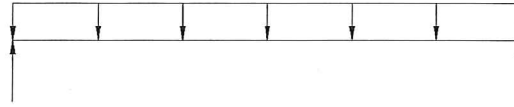

ANALYSIS:

R_{MAX} = K

V_D = K

< V_{ALL} = K

ADEQUATE

M_{MAX} = K-FT

< M_{ALL} = K-FT

ADEQUATE

Δ_{TL} = IN.

L/ < L/240

ADEQUATE

3 1/2" x 11 7/8" LVL

BEAM DESCRIPTION:

PARAMETERS:

L = FT

W = KLF

P = K

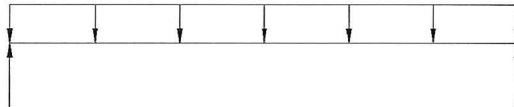

ANALYSIS:

R_{MAX} = K

V_D = K

< V_{ALL} = K

ADEQUATE

M_{MAX} = K-FT

< M_{ALL} = K-FT

ADEQUATE

Δ_{TL} = IN.

L/ < L/240

ADEQUATE

BEAM DESCRIPTION:

PARAMETERS:

L = FT

W = KLF

P = K

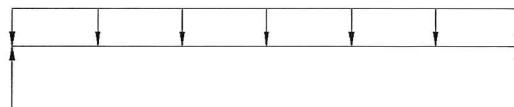

ANALYSIS:

R_{MAX} = K

V_D = K

< V_{ALL} = K

ADEQUATE

M_{MAX} = K-FT

< M_{ALL} = K-FT

ADEQUATE

Δ_{TL} = IN.

L/ < L/240

ADEQUATE



OVERSTRENGTH CALCULATIONS

WALL DESCRIPTION/SW #: 206

PARAMETERS:

- L = FT
- H = FT
- E = K
- W_{DL WALL} = KLF
- W_{DL} = KLF
- Ω₀ = (ASCE TABLE 12.2.1 FOOTNOTE 6)
- SDS =

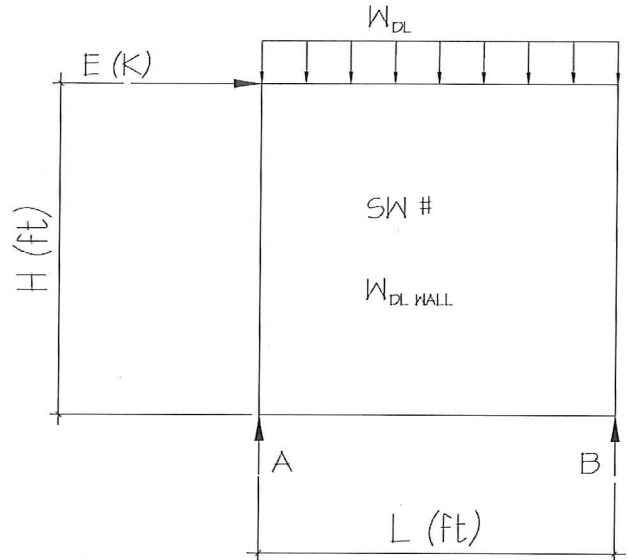

ANALYSIS:

$$E_{MH} = \Omega_0 * E = \boxed{5.56} \text{ K} \qquad E_v = 0.2 * SDS * DL = \boxed{1.06} \text{ K}$$

$$E_M = E_{MH} + E_v = \boxed{6.62} \text{ K}$$

$$E_M = E_{MH} - E_v = \boxed{4.5} \text{ K}$$

$$E_M \text{ (MAX)} = \sum M_A = 0 = -(6.62)(8) - .34(17)(8.5) + 17 R_B \qquad R_B = \boxed{2.89D + 3.11E}$$

$$R_A = \boxed{2.89D - 3.11E}$$

$$E_M \text{ (MIN)} = \sum M_A = 0 = -(4.5)(8) - .34(17)(8.5) + 17 R_B \qquad R_B = \boxed{2.89D + 2.12E}$$

$$R_A = \boxed{2.89D - 2.12E}$$

CHECK BEAMS FOR AXIAL FORCES SHOWN USING LOAD COMBOS PER SECTION 12.4.3.1 (ASD)

ALLOWABLE STRESS PERMITTED TO BE INCREASED BY 1.2

SEE FOLLOWING BEAM
CALCS FOR LOAD
APPLICATION



OVERSTRENGTH CALCULATIONS

WALL DESCRIPTION/SW #: 103

PARAMETERS:

- L = FT
- H = FT
- E = K
- W_{DL WALL} = KLF
- W_{DL} = KLF
- Ω₀ = (ASCE TABLE 12.2.1 FOOTNOTE B)
- SDS =

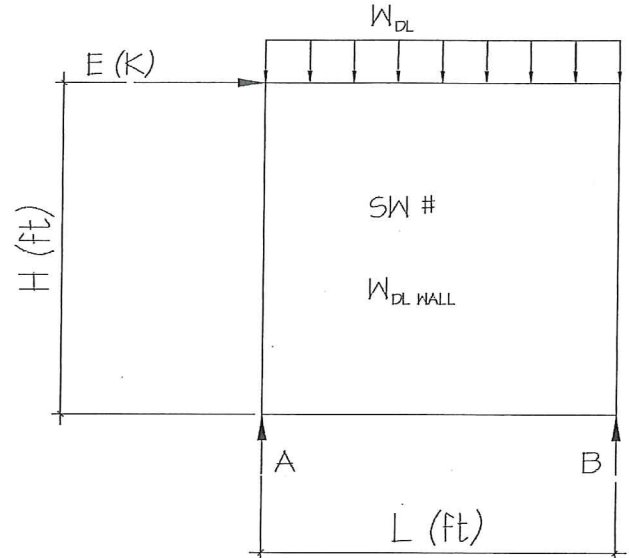

ANALYSIS:

$$E_{MH} = \Omega_0 * E = \boxed{5} \text{ K} \quad E_v = 0.2 * SDS * DL = \boxed{0.77} \text{ K}$$

$$E_M = E_{MH} + E_v = \boxed{5.77} \text{ K}$$

$$E_M = E_{MH} - E_v = \boxed{4.23} \text{ K}$$

$$E_M (\text{MAX}) = \sum M_A = 0 = -(5.77)(10) - .234(18)(9) + 18R_B$$

$$R_B = \boxed{2.10 + 3.21E}$$

$$R_A = \boxed{2.10 - 3.21E}$$

$$E_M (\text{MIN}) = \sum M_A = 0 = -(4.23)(10) - .234(18)(9) + 18R_B$$

$$R_B = \boxed{2.10 + 2.35}$$

$$R_A = \boxed{2.10 - 2.35}$$

CHECK BEAMS FOR AXIAL FORCES SHOWN USING LOAD COMBOS PER SECTION 12.4.3.1 (ASD)

ALLOWABLE STRESS PERMITTED TO BE INCREASED BY 1.2

SEE FOLLOWING BEAM
CALCS FOR LOAD
APPLICATION

OVERSTRENGTH CALCULATIONS

WALL DESCRIPTION/SW #: 112

PARAMETERS:

- L = FT
- H = FT
- E = K
- W_{DL WALL} = KLF
- W_{DL} = KLF
- Ω₀ = (ASCE TABLE 12.2.1 FOOTNOTE B)
- SDS =

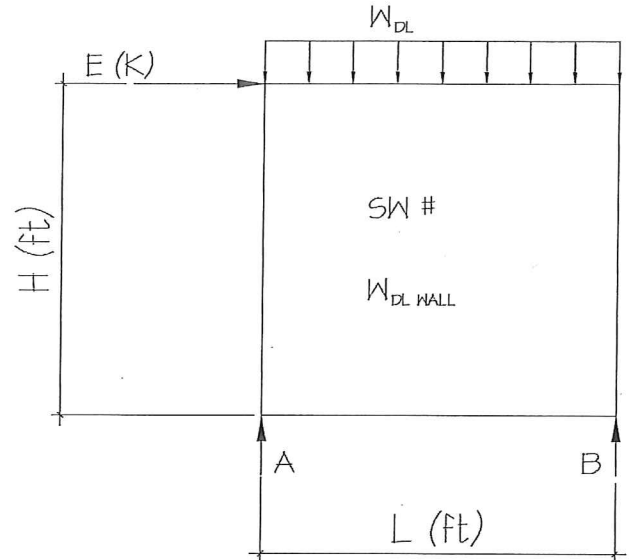

ANALYSIS:

$$E_{MH} = \Omega_0 * E = \text{2.5 K}$$

$$E_v = 0.2 * SDS * DL = \text{0.57 K}$$

$$E_M = E_{MH} + E_v = \text{3.07 K}$$

$$E_M = E_{MH} - E_v = \text{1.93 K}$$

$$E_M (MAX) = \sum M_A = 0 = -(3.07)(10) - .234(13.16)\left(\frac{13.16}{2}\right) + 13.16 R_B$$

$$R_B = \text{1.54D} + \text{2.33E}$$

$$R_A = \text{1.54D} - \text{2.33E}$$

$$E_M (MIN) = \sum M_A = 0 = -(1.93)(10) - .234(13.16)\left(\frac{13.16}{2}\right) + 13.16 R_B$$

$$R_B = \text{1.54D} + \text{1.47E}$$

$$R_A = \text{1.54D} - \text{1.47E}$$

CHECK BEAMS FOR AXIAL FORCES SHOWN USING LOAD COMBOS PER SECTION 12.4.3.1 (ASD)

ALLOWABLE STRESS PERMITTED TO BE INCREASED BY 1.2

SEE FOLLOWING BEAM
CALCS FOR LOAD
APPLICATION

Project Title:
 Engineer:
 Project ID:
 Project Descr:

Steel Beam

File = P:\CYJ7GB-PI0G6KEP-312018\190FZT-V\Design(Gravity)\Overstrength.ec6 .
 Software copyright ENERCALC, INC. 1983-2018, Build:10.18.12.13 .

Lic. # : KW-06004787

Licensee : MULHERN & KULP STRUCTURAL ENGINEERING INC

Description : B15 - Flush Beam at Living Room

CODE REFERENCES

Calculations per AISC 360-10, IBC 2015, CBC 2016, ASCE 7-10
 Load Combination Set : ASCE 7-10

Material Properties

Analysis Method : Allowable Strength Design
 Beam Bracing : Beam is Fully Braced against lateral-torsional buckling
 Bending Axis : Major Axis Bending
 Fy : Steel Yield : 50.0 ksi
 E : Modulus : 29,000.0 ksi

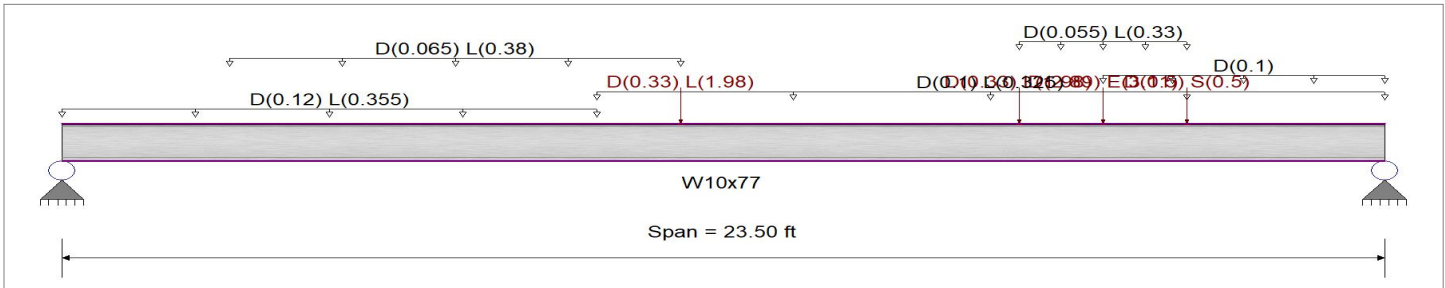

Applied Loads

Service loads entered. Load Factors will be applied for calculations.

Beam self weight calculated and added to loading

Load for Span Number 1

Uniform Load : D = 0.120, L = 0.3550 k/ft, Extent = 0.0 ---> 9.50 ft, Tributary Width = 1.0 ft

Point Load : D = 2.890, E = 3.110 k @ 18.50 ft

Uniform Load : D = 0.10, L = 0.3250 k/ft, Extent = 9.50 ---> 23.50 ft, Tributary Width = 1.0 ft

Uniform Load : D = 0.10 k/ft, Extent = 18.50 ---> 23.50 ft, Tributary Width = 1.0 ft

Uniform Load : D = 0.0650, L = 0.380 k/ft, Extent = 3.0 ---> 11.0 ft, Tributary Width = 1.0 ft

Uniform Load : D = 0.0550, L = 0.330 k/ft, Extent = 17.0 ---> 20.0 ft, Tributary Width = 1.0 ft

Point Load : D = 0.330, L = 1.980 k @ 17.0 ft

Point Load : D = 0.330, L = 1.980 k @ 11.0 ft

Point Load : D = 0.50, S = 0.50 k @ 20.0 ft

DESIGN SUMMARY

Design OK

Maximum Bending Stress Ratio =	0.330 : 1	Maximum Shear Stress Ratio =	0.125 : 1
Section used for this span	W10x77	Section used for this span	W10x77
Ma : Applied	80.381 k-ft	Va : Applied	14.023 k
Mn / Omega : Allowable	243.513 k-ft	Vn/Omega : Allowable	112.360 k
Load Combination	+D+L	Load Combination	+1.090D+0.750L+0.750S+0.5250E
Location of maximum on span	11.011 ft	Location of maximum on span	23.500 ft
Span # where maximum occurs	Span # 1	Span # where maximum occurs	Span # 1
Maximum Deflection			
Max Downward Transient Deflection	0.400 in	Ratio =	704 >=360
Max Upward Transient Deflection	0.000 in	Ratio =	0 <360
Max Downward Total Deflection	0.609 in	Ratio =	463 >=300
Max Upward Total Deflection	0.000 in	Ratio =	0 <300

Vertical Reactions

Support notation : Far left is #1

Values in KIPS

Load Combination	Support 1	Support 2
Overall MAXimum	11.633	14.023

Project Title:
 Engineer:
 Project ID:
 Project Descr:

Steel Beam

File = P:\CYJ7GB-PI0G6KEP-3\2018\190FZT-V\Design(Gravity)\Overstrength.ec6 .
 Software copyright ENERCALC, INC. 1983-2018, Build:10.18.12.13 .

Lic. # : KW-06004787

Licensee : MULHERN & KULP STRUCTURAL ENGINEERING INC

Description : B15 - Flush Beam at Living Room

Vertical Reactions

Support notation : Far left is #1

Values in KIPS

Load Combination	Support 1	Support 2
Overall MINimum	0.074	0.426
D Only	3.641	5.944
+D+L	11.633	13.864
+D+Lr	3.641	5.944
+D+S	3.715	6.369
+D+0.750Lr+0.750L	9.635	11.884
+D+0.750L+0.750S	9.691	12.203
+D+0.60W	3.641	5.944
+1.126D+0.70E	4.563	8.406
+D+0.750Lr+0.750L+0.450W	9.635	11.884
+D+0.750L+0.750S+0.450W	9.691	12.203
+1.090D+0.750L+0.750S+0.5250E	10.366	14.023
+0.60D+0.60W	2.185	3.566
+0.470D+0.70E	2.174	4.507
D Only	3.641	5.944
Lr Only		
L Only	7.992	7.920
S Only	0.074	0.426
W Only		
E Only	0.662	2.448
H Only		

Project Title:
 Engineer:
 Project ID:
 Project Descr:

Wood Beam

File = P:\CYJ7GB-PI0G6KEP-312018\190FZT-V\Design(Gravity)\Overstrength.ec6 .
 Software copyright ENERCALC, INC. 1983-2018, Build:10.18.12.13 .

Lic. # : KW-06004787

Licensee : MULHERN & KULP STRUCTURAL ENGINEERING INC

Description : B28 - Flush Beam at Storage/Utility

CODE REFERENCES

Calculations per NDS 2015, IBC 2015, CBC 2016, ASCE 7-10

Load Combination Set : ASCE 7-10

Material Properties

Analysis Method : Allowable Stress Design
 Load Combination : ASCE 7-10

Wood Species : iLevel Truss Joist
 Wood Grade : MicroLam LVL 1.9 E

Beam Bracing : Beam is Fully Braced against lateral-torsional buckling

Fb + 3,120.0 psi E : Modulus of Elasticity
 Fb - 3,120.0 psi Ebend- xx 2,000.0 ksi
 Fc - Prll 3,012.0 psi Eminbend - xx 965.71 ksi
 Fc - Perp 900.0 psi
 Fv 342.0 psi
 Ft 1,866.0 psi Density 32.210pcf

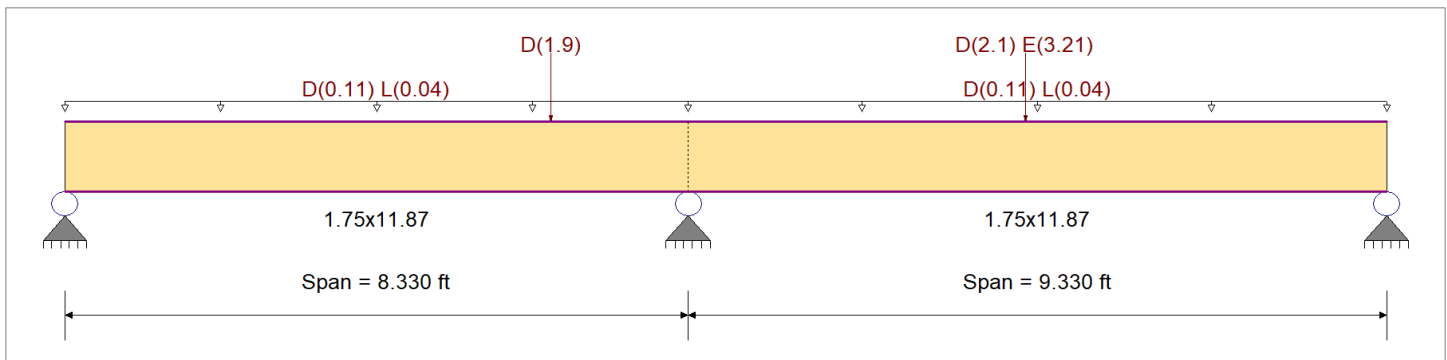

Applied Loads

Service loads entered. Load Factors will be applied for calculations.

Beam self weight calculated and added to loads

Load for Span Number 1

Uniform Load : D = 0.110, L = 0.040, Tributary Width = 1.0 ft

Point Load : D = 1.90 k @ 6.50 ft

Load for Span Number 2

Uniform Load : D = 0.110, L = 0.040, Tributary Width = 1.0 ft

Point Load : D = 2.10, E = 3.210 k @ 4.50 ft

DESIGN SUMMARY

Design OK

Maximum Bending Stress Ratio	=	0.499	1	Maximum Shear Stress Ratio	=	0.552	1
Section used for this span		1.75x11.87		Section used for this span		1.75x11.87	
fb : Actual	=	2,492.73	psi	fv : Actual	=	170.04	psi
FB : Allowable	=	4,992.00	psi	Fv : Allowable	=	307.80	psi
Load Combination		+1.126D+0.70E		Load Combination		D Only	
Location of maximum on span	=	4.535	ft	Location of maximum on span	=	7.353	ft
Span # where maximum occurs	=	Span # 2		Span # where maximum occurs	=	Span # 1	
Maximum Deflection							
Max Downward Transient Deflection		0.135	in	Ratio =		829	>=360
Max Upward Transient Deflection		-0.048	in	Ratio =		2101	>=360
Max Downward Total Deflection		0.190	in	Ratio =		588	>=300
Max Upward Total Deflection		-0.029	in	Ratio =		3406	>=300

Maximum Forces & Stresses for Load Combinations

Load Combination	Segment Length	Span #	Max Stress Ratios								Moment Values			Shear Values			
			M	V	C _d	C _{F/V}	C _i	C _r	C _m	C _t	C _L	M	fb	F'b	V	fv	F'v
D Only																	
Length = 8.330 ft	1		0.439	0.552	0.90	1.000	1.00	1.00	1.00	1.00	1.00	4.23	1,233.74	2808.00	2.36	170.04	307.80
Length = 9.330 ft	2		0.439	0.552	0.90	1.000	1.00	1.00	1.00	1.00	1.00	4.23	1,233.74	2808.00	1.97	170.04	307.80
+D+L, LL Comb Run (*L)																	
Length = 8.330 ft	1		0.417	0.503	1.00	1.000	1.00	1.00	1.00	1.00	1.00	4.46	1,300.83	3120.00	2.38	172.03	342.00

Project Title:
 Engineer:
 Project ID:
 Project Descr:

Wood Beam

File = P:\CYJ7GB-PI0G6KEP-312018\19OFZT-V\Design(Gravity)\Overstrength.ec6 .
 Software copyright ENERCALC, INC. 1983-2018, Build:10.18.12.13 .

Lic. # : KW-06004787

Licensee : MULHERN & KULP STRUCTURAL ENGINEERING INC

Description : B28 - Flush Beam at Storage/Utility

Load Combination	Segment Length	Span #	Max Stress Ratios								Moment Values			Shear Values			
			M	V	C _d	C _{F/V}	C _i	C _r	C _m	C _t	C _L	M	fb	F'b	V	fv	F'v
+D+0.750L+0.750S+0.450W, LL Co	Length = 9.330 ft	2	0.254	0.325	1.60	1.000	1.00	1.00	1.00	1.00	1.00	4.35	1,269.55	4992.00	1.98	178.00	547.20
	Length = 8.330 ft	1	0.264	0.328	1.60	1.000	1.00	1.00	1.00	1.00	1.00	4.52	1,319.86	4992.00	0.00	0.00	0.00
+1.090D+0.750L+0.750S+0.5250E,	Length = 9.330 ft	2	0.264	0.328	1.60	1.000	1.00	1.00	1.00	1.00	1.00	4.52	1,319.86	4992.00	2.49	179.50	547.20
	Length = 8.330 ft	1	0.371	0.437	1.60	1.000	1.00	1.00	1.00	1.00	1.00	6.36	1,854.30	4992.00	0.00	0.00	0.00
+1.090D+0.750L+0.750S+0.5250E,	Length = 9.330 ft	2	0.445	0.437	1.60	1.000	1.00	1.00	1.00	1.00	1.00	7.61	2,220.36	4992.00	3.32	239.36	547.20
	Length = 8.330 ft	1	0.369	0.422	1.60	1.000	1.00	1.00	1.00	1.00	1.00	6.31	1,839.79	4992.00	0.00	0.00	0.00
+1.090D+0.750L+0.750S+0.5250E,	Length = 9.330 ft	2	0.427	0.422	1.60	1.000	1.00	1.00	1.00	1.00	1.00	7.31	2,132.65	4992.00	3.20	230.91	547.20
	Length = 8.330 ft	1	0.379	0.439	1.60	1.000	1.00	1.00	1.00	1.00	1.00	6.48	1,890.11	4992.00	0.00	0.00	0.00
+1.090D+0.750L+0.750S-0.5250E,	Length = 9.330 ft	2	0.441	0.439	1.60	1.000	1.00	1.00	1.00	1.00	1.00	7.55	2,201.95	4992.00	3.33	240.31	547.20
	Length = 8.330 ft	1	0.187	0.317	1.60	1.000	1.00	1.00	1.00	1.00	1.00	3.21	935.88	4992.00	0.00	0.00	0.00
+1.090D+0.750L+0.750S-0.5250E,	Length = 9.330 ft	2	0.187	0.317	1.60	1.000	1.00	1.00	1.00	1.00	1.00	3.21	935.88	4992.00	3.33	240.31	547.20
	Length = 8.330 ft	1	0.185	0.328	1.60	1.000	1.00	1.00	1.00	1.00	1.00	3.16	921.37	4992.00	0.00	0.00	0.00
+1.090D+0.750L+0.750S-0.5250E,	Length = 9.330 ft	2	0.185	0.328	1.60	1.000	1.00	1.00	1.00	1.00	1.00	3.16	921.37	4992.00	2.49	179.67	547.20
	Length = 8.330 ft	1	0.195	0.331	1.60	1.000	1.00	1.00	1.00	1.00	1.00	3.33	971.69	4992.00	1.12	179.67	547.20
+0.60D+0.60W	Length = 9.330 ft	2	0.195	0.331	1.60	1.000	1.00	1.00	1.00	1.00	1.00	3.33	971.69	4992.00	0.00	0.00	0.00
	Length = 8.330 ft	1	0.148	0.186	1.60	1.000	1.00	1.00	1.00	1.00	1.00	2.54	740.24	4992.00	0.00	0.00	0.00
+0.470D+0.70E	Length = 9.330 ft	2	0.148	0.186	1.60	1.000	1.00	1.00	1.00	1.00	1.00	2.54	740.24	4992.00	1.41	102.02	547.20
	Length = 8.330 ft	1	0.239	0.305	1.60	1.000	1.00	1.00	1.00	1.00	1.00	4.09	1,192.14	4992.00	1.18	102.02	547.20
+0.470D-0.70E	Length = 9.330 ft	2	0.349	0.305	1.60	1.000	1.00	1.00	1.00	1.00	1.00	5.97	1,741.00	4992.00	0.00	0.00	0.00
	Length = 8.330 ft	1	0.098	0.113	1.60	1.000	1.00	1.00	1.00	1.00	1.00	1.68	490.08	4992.00	2.31	166.95	547.20
	Length = 9.330 ft	2	0.133	0.113	1.60	1.000	1.00	1.00	1.00	1.00	1.00	2.28	665.43	4992.00	0.00	0.00	0.00
	Length = 8.330 ft	1	0.098	0.113	1.60	1.000	1.00	1.00	1.00	1.00	1.00	1.68	490.08	4992.00	0.86	61.73	547.20

Overall Maximum Deflections

Load Combination	Span	Max. "-" Defl	Location in Span	Load Combination	Max. "+" Defl	Location in Span
+1.126D+0.70E	1	0.0000	0.000	E Only	-0.0476	4.840
	2	0.1903	4.952		0.0000	4.840

Vertical Reactions

Support notation : Far left is #1

Values in KIPS

Load Combination	Support 1	Support 2	Support 3
Overall MAXimum	0.534	6.755	2.091
Overall MINimum	0.119	2.343	1.227
D Only	0.387	4.543	1.094
+D+L, LL Comb Run (*L)	0.360	4.782	1.256
+D+L, LL Comb Run (L*)	0.534	4.747	1.077
+D+L, LL Comb Run (LL)	0.507	4.986	1.239
+D+Lr, LL Comb Run (*L)	0.387	4.543	1.094
+D+Lr, LL Comb Run (L*)	0.387	4.543	1.094
+D+Lr, LL Comb Run (LL)	0.387	4.543	1.094
+D+S	0.387	4.543	1.094
+D+0.750Lr+0.750L, LL Comb Run (*L)	0.367	4.722	1.216
+D+0.750Lr+0.750L, LL Comb Run (L*)	0.497	4.696	1.081
+D+0.750Lr+0.750L, LL Comb Run (LL)	0.477	4.875	1.203
+D+0.750L+0.750S, LL Comb Run (*L)	0.367	4.722	1.216
+D+0.750L+0.750S, LL Comb Run (L*)	0.497	4.696	1.081
+D+0.750L+0.750S, LL Comb Run (LL)	0.477	4.875	1.203
+D+0.60W	0.387	4.543	1.094
+1.126D+0.70E	0.184	6.755	2.091
+D+0.750Lr+0.750L+0.450W, LL Comb R	0.367	4.722	1.216
+D+0.750Lr+0.750L+0.450W, LL Comb R	0.497	4.696	1.081
+D+0.750Lr+0.750L+0.450W, LL Comb R	0.477	4.875	1.203

Project Title:
 Engineer:
 Project ID:
 Project Descr:

Wood Beam

File = P:\CYJ7GB-PI0G6KEP-3\2018\190FZT-V\Design(Gravity)\Overstrength.ec6 .
 Software copyright ENERCALC, INC. 1983-2018, Build:10.18.12.13 .

Lic. # : KW-06004787

Licensee : MULHERN & KULP STRUCTURAL ENGINEERING INC

Description : B28 - Flush Beam at Storage/Utility

Load Combination	Support notation : Far left is #1			Values in KIPS
	Support 1	Support 2	Support 3	
+D+0.750L+0.750S+0.450W, LL Comb Ru	0.367	4.722	1.216	
+D+0.750L+0.750S+0.450W, LL Comb Ru	0.497	4.696	1.081	
+D+0.750L+0.750S+0.450W, LL Comb Ru	0.477	4.875	1.203	
+1.090D+0.750L+0.750S+0.5250E, LL C	0.212	6.361	1.959	
+1.090D+0.750L+0.750S+0.5250E, LL C	0.343	6.335	1.824	
+1.090D+0.750L+0.750S+0.5250E, LL C	0.323	6.514	1.945	
+0.60D+0.60W	0.232	2.726	0.657	
+0.470D+0.70E	-0.070	3.775	1.373	
D Only	0.387	4.543	1.094	
Lr Only, LL Comb Run (*L)				
Lr Only, LL Comb Run (L*)				
Lr Only, LL Comb Run (LL)				
L Only, LL Comb Run (*L)	-0.028	0.239	0.162	
L Only, LL Comb Run (L*)	0.147	0.204	-0.018	
L Only, LL Comb Run (LL)	0.119	0.443	0.144	
S Only				
W Only				
E Only	-0.360	2.343	1.227	
H Only				

This Wall in File: P:\Client Files\01A - Architectural Miscellaneous\2018\18094 - J Designs - 3440 9

RetainPro (c) 1987-2016, Build 11.16.11.12
License : KW-06059959
License To : **MULHERN & KULP STRUCTURAL ENGINEERING INC**

Restrained Retaining Wall

Code: IBC 2015,ACI 318-14,ACI 530-13

Criteria

Retained Height	=	9.00 ft
Wall height above soil	=	0.00 ft
Total Wall Height	=	9.00 ft
Top Support Height	=	9.00 ft
Slope Behind Wall	=	0.00
Height of Soil over Toe	=	36.00 in

Soil Data

Allow Soil Bearing	=	2,500.0 psf
Equivalent Fluid Pressure Method		
At-rest Heel Pressure	=	35.0 psf/ft
Passive Pressure	=	250.0 psf/ft
Soil Density	=	110.00 pcf
Footing Soil Frictior	=	0.400
Soil height to ignore for passive pressure	=	12.00 in

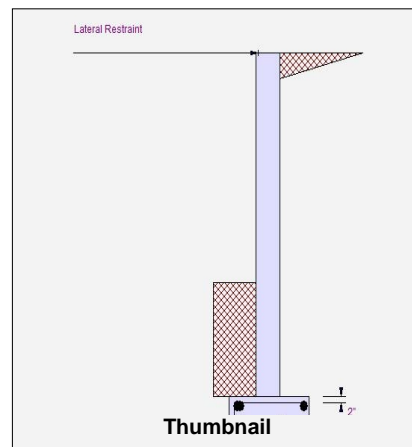

Surcharge Loads

Surcharge Over Heel	=	0.0 psf
>>>Used To Resist Sliding & Overturning		
Surcharge Over Toe	=	0.0 psf
Used for Sliding & Overturning		

Uniform Lateral Load Applied to Stem

Lateral Load	=	0.0 #/ft
...Height to Top	=	0.00 ft
...Height to Bottom	=	0.00 ft
Load Type	=	Wind (W) (Strength Level)

Adjacent Footing Load

Adjacent Footing Load	=	0.0 lbs
Footing Width	=	0.00 ft
Eccentricity	=	0.00 in
Wall to Ftg CL Dist	=	0.00 ft
Footing Type	=	Line Load
Base Above/Below Soil at Back of Wall	=	0.0 ft
Poisson's Ratio	=	0.300

Axial Load Applied to Stem

Axial Dead Load	=	100.0 lbs
Axial Live Load	=	0.0 lbs
Axial Load Eccentricity	=	0.0 in

Wind on Exposed Stem	=	0.0 psf
----------------------	---	---------

Earth Pressure Seismic Load

K_h Soil Density Multiplier	=	0.200 g	Added seismic per unit area	=	0.0 psf
-------------------------------	---	---------	-----------------------------	---	---------

Stem Weight Seismic Load

F_p / W_p Weight Multiplier	=	0.000 g	Added seismic per unit area	=	0.0 psf
-------------------------------	---	---------	-----------------------------	---	---------

Design Summary

Total Bearing Load	=	2,585 lbs
...resultant ecc.	=	5.67 in
Soil Pressure @ Toe	=	2,217 psf OK
Soil Pressure @ Heel	=	0 psf OK
Allowable	=	2,500 psf
Soil Pressure Less Than Allowable		
ACI Factored @ Toe	=	2,661 psf
ACI Factored @ Heel	=	0 psf
Footing Shear @ Toe	=	4.0 psi OK
Footing Shear @ Heel	=	8.2 psi OK
Allowable	=	75.0 psi
Reaction at Top	=	282.5 lbs
Reaction at Bottom	=	1,466.5 lbs
Sliding Stability Ratio	=	1.98 OK
Sliding Calcs		
Lateral Sliding Force	=	1,466.5 lbs
less 100% Passive Force	=	- 1,875.0 lbs
less 100% Friction Force	=	- 1,034.0 lbs
Added Force Req'd	=	0.0 lbs OK
...for 1.5 Stability	=	0.0 lbs OK

Concrete Stem Construction

Thickness	=	8.00 in	F_y	=	60,000 psi
Wall Weight	=	100.0 psf	f'_c	=	3,000 psi
Stem is FIXED to top of footing					

	@ Top Support	Mmax Between Top & Base	@ Base of Wall
Design Height Above Ftg	Stem OK = 9.00 ft	Stem OK = 5.02 ft	Stem OK = 0.00 ft
Rebar Size	# 5	# 5	# 4
Rebar Spacing	16.00 in	16.00 in	12.00 in
Rebar Placed at	Edge	Edge	Edge
Rebar Depth 'd'	5.50 in	6.00 in	5.50 in
Design Data			
fb/FB + fa/Fa	= 0.000	0.202	0.570
Mu....Actual	= 0.0 ft-#	1,217.1 ft-#	2,721.7 ft-#
Mn * Phi....Allowable	= 5,515.2 ft-#	6,038.3 ft-#	4,773.0 ft-#
Shear Force @ this height	= 453.6 lbs		1,814.4 lbs
Shear.....Actual	= 6.87 psi		27.49 psi
Shear.....Allowable	= 82.16 psi		82.16 psi

Vertical component of active lateral soil pressure IS NOT considered in the calculation of soil bearing

Load Factors

Building Code	IBC 2015,ACI
Dead Load	1.200
Live Load	1.600
Earth, H	1.600
Wind, W	1.000
Seismic, E	1.000

Other Acceptable Sizes & Spacings:

Toe: # 4 @ 18.00 in	-or-	Not req'd: $M_u < \phi * \lambda * \sqrt{f'_c} * S_m$
Heel: # 4 @ 18.00 in	-or-	Not req'd: $M_u < \phi * \lambda * \sqrt{f'_c} * S_m$
Key: No key defined	-or-	No key defined

This Wall in File: P:\Client Files\01A - Architectural Miscellaneous\2018\18094 - J Designs - 3440 9

RetainPro (c) 1987-2016, Build 11.16.11.12
License : KW-06059959
License To : MULHERN & KULP STRUCTURAL ENGINEERING INC

Restrained Retaining Wall

Code: IBC 2015,ACI 318-14,ACI 530-13

Concrete Stem Rebar Area Details

Top Support	Vertical Reinforcing	Horizontal Reinforcing
As (based on applied moment) :	0 in2/ft	
(4/3) * As :	0 in2/ft	Min Stem T&S Reinf Area 1.728 in2
200bd/ft : 200(12)(5.5)/60000 :	0.22 in2/ft	Min Stem T&S Reinf Area per ft of stem Height : 0.192 in2/ft
0.0018bh : 0.0018(12)(8) :	0.1728 in2/ft	Horizontal Reinforcing Options :
	=====	One layer of : Two layers of :
Required Area :	0.1728 in2/ft	#4@ 12.50 in #4@ 25.00 in
Provided Area :	0.2325 in2/ft	#5@ 19.38 in #5@ 38.75 in
Maximum Area :	0.8941 in2/ft	#6@ 27.50 in #6@ 55.00 in

Mmax Between Ends	Vertical Reinforcing	Horizontal Reinforcing
As (based on applied moment) :	0.0476 in2/ft	
(4/3) * As :	0.0635 in2/ft	Min Stem T&S Reinf Area 0.763 in2
200bd/ft : 200(12)(6)/60000 :	0.24 in2/ft	Min Stem T&S Reinf Area per ft of stem Height : 0.192 in2/ft
0.0018bh : 0.0018(12)(8) :	0.1728 in2/ft	Horizontal Reinforcing Options :
	=====	One layer of : Two layers of :
Required Area :	0.1728 in2/ft	#4@ 12.50 in #4@ 25.00 in
Provided Area :	0.2325 in2/ft	#5@ 19.38 in #5@ 38.75 in
Maximum Area :	0.9754 in2/ft	#6@ 27.50 in #6@ 55.00 in

Base Support	Vertical Reinforcing	Horizontal Reinforcing
As (based on applied moment) :	0.1167 in2/ft	
(4/3) * As :	0.1556 in2/ft	Min Stem T&S Reinf Area 0.965 in2
200bd/ft : 200(12)(5.5)/60000 :	0.22 in2/ft	Min Stem T&S Reinf Area per ft of stem Height : 0.192 in2/ft
0.0018bh : 0.0018(12)(8) :	0.1728 in2/ft	Horizontal Reinforcing Options :
	=====	One layer of : Two layers of :
Required Area :	0.1728 in2/ft	#4@ 12.50 in #4@ 25.00 in
Provided Area :	0.2 in2/ft	#5@ 19.38 in #5@ 38.75 in
Maximum Area :	0.8941 in2/ft	#6@ 27.50 in #6@ 55.00 in

Footing Strengths & Dimensions

Toe Width	=	0.92 ft
Heel Width	=	1.58
Total Footing Width	=	2.50
Footing Thickness	=	12.00 in
Key Width	=	0.00 in
Key Depth	=	0.00 in
Key Distance from Toe	=	0.00 ft
f'c =	2,500 psi	Fy = 60,000 psi
Footing Concrete Density	=	150.00 pcf
Min. As %	=	0.0018
Cover @ Top	=	2.00 in @ Btm.= 3.00 in

Footing Design Results

	Toe	Heel
Factored Pressure	= 2,661	0 psf
Mu' : Upward	= 971	80 ft-#
Mu' : Downward	= 242	575 ft-#
Mu: Design	= 729	495 ft-#
Actual 1-Way Shear	= 4.02	8.20 psi
Allow 1-Way Shear	= 75.00	75.00 psi
Min footing T&S reinf Area	0.65	in2
Min footing T&S reinf Area per foot	0.26	in2 /ft
If one layer of horizontal bars:		If two layers of horizontal bars:
#4@ 9.26 in		#4@ 18.52 in
#5@ 14.35 in		#5@ 28.70 in
#6@ 20.37 in		#6@ 40.74 in

Summary of Forces on Footing : Slab is NOT providing sliding, stem is FIXED at footing

Forces acting on footing for sliding & soil pressure....

Sliding Forces

Stem Shear @ Top of Footing	=	-1,134.0 lbs
Heel Active Pressure	=	-332.5
Sliding Force	=	1,466.5 lbs

Net Moment User For Soil Pressure Calculations
1,222.1 ft-#

Load & Moment Summary For Footing : For Soil Pressure Calcs

Moment @ Top of Footing Applied from Stem	=	-1,701.0ft-#
Surcharge Over Heel		
Adjacent Footing Load	=	lbs ft ft-#
Axial Dead Load on Stem	=	100.0 lbs 1.25 ft 125.0ft-#
Soil Over Toe	=	302.5 lbs 0.46 ft 138.6ft-#
Surcharge Over Toe	=	lbs ft ft-#
Stem Weight	=	900.0 lbs 1.25 ft 1,125.0ft-#
Soil Over Heel	=	907.5 lbs 2.04 ft 1,852.8ft-#
Footing Weight	=	375.0 lbs 1.25 ft 468.8ft-#
Total Vertical Force	≡	2,585.0 lbs
Base Moment	=	2,009.2ft-#

Use menu item Settings > Printing & Title Block
to set these five lines of information
for your program.

Title **3440 97th Ave**
Job # : Dsgnr: **NJD**
Description....
DTL 14 - Reverse Retaining at Garage

Page : 3
Date: 21 JAN 2019

This Wall in File: P:\Client Files\01A - Architectural Miscellaneous\2018\18094 - J Designs - 3440 9

RetainPro (c) 1987-2016, Build 11.16.11.12
License : KW-06059959
License To : **MULHERN & KULP STRUCTURAL ENGINEERING INC**

Restrained Retaining Wall

Code: IBC 2015,ACI 318-14,ACI 530-13

Vertical component of active lateral soil pressure IS NOT considered in
the calculation of Sliding Resistance.

This Wall in File: P:\Client Files\01A - Architectural Miscellaneous\2018\18094 - J Designs - 3440 9

RetainPro (c) 1987-2016, Build 11.16.11.12
License : KW-06059959
License To : MULHERN & KULP STRUCTURAL ENGINEERING INC

Cantilevered Retaining Wall

Code: IBC 2015,ACI 318-14,ACI 530-13

Criteria

Retained Height	=	9.00 ft
Wall height above soil	=	0.00 ft
Slope Behind Wall	=	0.00
Height of Soil over Toe	=	0.00 in
Water height over heel	=	0.0 ft

Soil Data

Allow Soil Bearing	=	2,500.0 psf
Equivalent Fluid Pressure Method		
Active Heel Pressure	=	55.0 psf/ft
	=	
Passive Pressure	=	250.0 psf/ft
Soil Density, Heel	=	110.00 pcf
Soil Density, Toe	=	0.00 pcf
Footing Soil Friction	=	0.400
Soil height to ignore for passive pressure	=	12.00 in

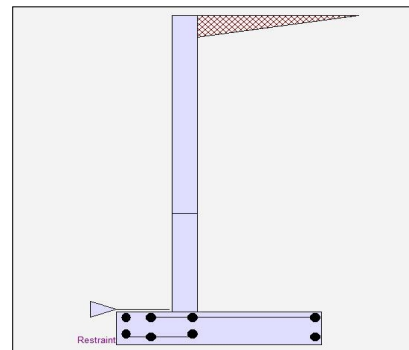

Surcharge Loads

Surcharge Over Heel	=	0.0 psf
Used To Resist Sliding & Overturning		
Surcharge Over Toe	=	0.0 psf
Used for Sliding & Overturning		

Lateral Load Applied to Stem

Lateral Load	=	0.0 #/ft
...Height to Top	=	0.00 ft
...Height to Bottom	=	0.00 ft
Load Type	=	Wind (W) (Service Level)
Wind on Exposed Stem	=	0.0 psf (Service Level)

Adjacent Footing Load

Adjacent Footing Load	=	0.0 lbs
Footing Width	=	0.00 ft
Eccentricity	=	0.00 in
Wall to Ftg CL Dist	=	0.00 ft
Footing Type		Line Load
Base Above/Below Soil at Back of Wall	=	0.0 ft
Poisson's Ratio	=	0.300

Axial Load Applied to Stem

Axial Dead Load	=	0.0 lbs
Axial Live Load	=	0.0 lbs
Axial Load Eccentricity	=	0.0 in

Design Summary

Wall Stability Ratios

Overturning	=	1.81 OK
Slab Resists All Sliding !		
Total Bearing Load	=	5,025 lbs
...resultant ecc.	=	15.32 in
Soil Pressure @ Toe	=	2,274 psf OK
Soil Pressure @ Heel	=	0 psf OK
Allowable	=	2,500 psf
Soil Pressure Less Than Allowable		
ACI Factored @ Toe	=	3,184 psf
ACI Factored @ Heel	=	0 psf
Footing Shear @ Toe	=	21.1 psi OK
Footing Shear @ Heel	=	24.0 psi OK
Allowable	=	82.2 psi

Sliding Calcs

Lateral Sliding Force	=	2,750.0 lbs
-----------------------	---	-------------

Vertical component of active lateral soil pressure IS NOT considered in the calculation of soil bearing

Load Factors

Building Code	IBC 2015,ACI
Dead Load	1.200
Live Load	1.600
Earth, H	1.600
Wind, W	1.000
Seismic, E	1.000

Stem Construction

	2nd	Bottom
Design Height Above Ftg	ft = 3.00	Stem OK 0.00
Wall Material Above "Ht"	= Concrete	Concrete
Design Method	= LRFD	LRFD
Thickness	= 8.00	8.00
Rebar Size	= # 5	# 5
Rebar Spacing	= 16.00	8.00
Rebar Placed at	= 6.5 in	6.5 in
Design Data		
fb/FB + fa/Fa	= 0.483	0.846
Total Force @ Section		
Service Level	lbs =	
Strength Level	lbs = 1,584.0	3,564.0
Moment....Actual		
Service Level	ft-# =	
Strength Level	ft-# = 3,168.0	10,692.0
Moment....Allowable	ft-# = 6,561.4	12,644.5
Service Level	psi =	
Strength Level	psi = 20.3	45.7
Shear.....Allowable	psi = 82.2	82.2
Anet (Masonry)	in2 =	
Rebar Depth 'd'	in = 6.50	6.50

Masonry Data

f'm	psi =	
Fs	psi =	
Solid Grouting	=	
Modular Ratio 'n'	=	
Wall Weight	psf = 100.0	100.0
Short Term Factor	=	
Equiv. Solid Thick.	=	
Masonry Block Type	= Medium Weight	
Masonry Design Method	= ASD	

Concrete Data

f'c	psi = 3,000.0	3,000.0
Fy	psi = 60,000.0	60,000.0

This Wall in File: P:\Client Files\01A - Architectural Miscellaneous\2018\18094 - J Designs - 3440 9

RetainPro (c) 1987-2016, Build 11.16.11.12
License : KW-06059959
License To : MULHERN & KULP STRUCTURAL ENGINEERING INC

Cantilevered Retaining Wall

Code: IBC 2015,ACI 318-14,ACI 530-13

Concrete Stem Rebar Area Details

2nd Stem	Vertical Reinforcing	Horizontal Reinforcing
As (based on applied moment) :	0.1139 in2/ft	
(4/3) * As :	0.1519 in2/ft	Min Stem T&S Reinf Area 1.152 in2
200bd/fy : 200(12)(6.5)/60000 :	0.26 in2/ft	Min Stem T&S Reinf Area per ft of stem Height : 0.192 in2/ft
0.0018bh : 0.0018(12)(8) :	0.1728 in2/ft	Horizontal Reinforcing Options :
	=====	One layer of : Two layers of :
Required Area :	0.1728 in2/ft	#4@ 12.50 in #4@ 25.00 in
Provided Area :	0.2325 in2/ft	#5@ 19.38 in #5@ 38.75 in
Maximum Area :	1.0567 in2/ft	#6@ 27.50 in #6@ 55.00 in

Bottom Stem	Vertical Reinforcing	Horizontal Reinforcing
As (based on applied moment) :	0.3844 in2/ft	
(4/3) * As :	0.5125 in2/ft	Min Stem T&S Reinf Area 0.576 in2
200bd/fy : 200(12)(6.5)/60000 :	0.26 in2/ft	Min Stem T&S Reinf Area per ft of stem Height : 0.192 in2/ft
0.0018bh : 0.0018(12)(8) :	0.1728 in2/ft	Horizontal Reinforcing Options :
	=====	One layer of : Two layers of :
Required Area :	0.3844 in2/ft	#4@ 12.50 in #4@ 25.00 in
Provided Area :	0.465 in2/ft	#5@ 19.38 in #5@ 38.75 in
Maximum Area :	1.0567 in2/ft	#6@ 27.50 in #6@ 55.00 in

Footing Dimensions & Strengths

Toe Width	=	1.50 ft
Heel Width	=	4.00
Total Footing Width	=	5.50
Footing Thickness	=	12.00 in
Key Width	=	0.00 in
Key Depth	=	0.00 in
Key Distance from Toe	=	0.00 ft
f'c = 3,000 psi	Fy =	60,000 psi
Footing Concrete Density	=	150.00 pcf
Min. As %	=	0.0018
Cover @ Top 2.00	@ Btm.=	3.00 in

Footing Design Results

	Toe	Heel
Factored Pressure	= 3,184	0 psf
Mu' : Upward	= 3,177	1,372 ft-#
Mu' : Downward	= 203	7,600 ft-#
Mu: Design	= 2,974	6,228 ft-#
Actual 1-Way Shear	= 21.10	23.97 psi
Allow 1-Way Shear	= 82.16	82.16 psi
Toe Reinforcing	= # 4 @ 8.00 in	
Heel Reinforcing	= # 4 @ 8.00 in	
Key Reinforcing	= None Spec'd	

Other Acceptable Sizes & Spacings

Toe: #4@ 9.26 in, #5@ 14.35 in, #6@ 20.37 in, #7@ 27.78 in, #8@ 36.57 in, #9@ 46
Heel: #4@ 9.26 in, #5@ 14.35 in, #6@ 20.37 in, #7@ 27.78 in, #8@ 36.57 in, #9@ 46
Key: No key defined

Min footing T&S reinf Area	1.43 in2
Min footing T&S reinf Area per foot	0.26 in2 /ft
If one layer of horizontal bars:	If two layers of horizontal bars:
#4@ 9.26 in	#4@ 18.52 in
#5@ 14.35 in	#5@ 28.70 in
#6@ 20.37 in	#6@ 40.74 in

Use menu item Settings > Printing & Title Block
to set these five lines of information
for your program.

Title 3440 97th Ave
Job # : Dsgnr: NJD
Description....
DTL 15 - Cant'd Wall at Stairs

Page : 3
Date: 21 JAN 2019

This Wall in File: P:\Client Files\01A - Architectural Miscellaneous\2018\18094 - J Designs - 3440 9

RetainPro (c) 1987-2016, Build 11.16.11.12
License : KW-06059959
License To : MULHERN & KULP STRUCTURAL ENGINEERING INC

Cantilevered Retaining Wall

Code: IBC 2015,ACI 318-14,ACI 530-13

Summary of Overturning & Resisting Forces & Moments

ItemOVERTURNING.....		RESISTING.....				
	Force lbs	Distance ft	Moment ft-#	Force lbs	Distance ft	Moment ft-#		
Heel Active Pressure =	2,750.0	3.33	9,166.7	Soil Over Heel =	3,300.0	3.83	12,650.0	
Surcharge over Heel =				Sloped Soil Over Heel =				
Surcharge Over Toe =				Surcharge Over Heel =				
Adjacent Footing Load =				Adjacent Footing Load =				
Added Lateral Load =				Axial Dead Load on Stem =				
Load @ Stem Above Soil =				* Axial Live Load on Stem =				
				Soil Over Toe =				
				Surcharge Over Toe =				
Total	2,750.0	O.T.M.	9,166.7	Stem Weight(s) =	900.0	1.83	1,650.0	
				Earth @ Stem Transitions =				
				Footing Weight =	825.0	2.75	2,268.8	
Resisting/Overturning Ratio		=	1.81	Key Weight =				
Vertical Loads used for Soil Pressure =		5,025.0	lbs	Vert. Component =				
				Total =	5,025.0	lbs	R.M.=	16,568.8

* Axial live load NOT included in total displayed, or used for overturning resistance, but is included for soil pressure calculation.

Vertical component of active lateral soil pressure IS NOT considered in the calculation of Sliding Resistance.

Vertical component of active lateral soil pressure IS NOT considered in the calculation of Overturning Resistance.

Tilt

Horizontal Deflection at Top of Wall due to settlement of soil

(Deflection due to wall bending not considered)

Soil Spring Reaction Modulus 250.0 pci
Horizontal Defl @ Top of Wall (approximate only) 0.103 in

The above calculation is not valid if the heel soil bearing pressure exceeds that of the toe, because the wall would then tend to rotate into the retained soil.

J DESIGNS
3440 97TH AVE

MERCER ISLAND, WA

SHEAR WALL CALCULATIONS - WIND

REVIEWED BY:

JANUARY 21, 2019

PARAMETERS:

SINGLE FAMILY HOME

DESIGN WIND SPEED: 110 MPH

WIND EXPOSURE CATEGORY: C

SEISMIC DESIGN CATEGORY: D

CODE & DESIGN STANDARD: 2015 IBC CH. 1609, ASCE 7-10 CH. 26-30



WIND DESIGN SUMMARY PER ASCE 7-10

PARAMETERS:

WIND SPEED	110
EXPOSURE CATEGORY	C
RISK CATEGORY	II
WIND DIRECTIONALITY FACTOR, K_d	0.85
TOPOGRAPHIC FACTOR, K_{zt}	1.00
GUST FACTOR, G	0.85
DESIGN TYPE	ASD

ROOF GEOMETRY:

TRANS. ROOF PITCH	3	:12
LONG. ROOF PITCH	3	:12
MEAN ROOF HEIGHT, H	31.00	FT

BUILDING GEOMETRY:

LENGTH	52	FT
WIDTH	64	FT
NUMBER OF STORIES	3	

TRANSVERSE DIRECTION (PERPENDICULAR TO MAIN RIDGE LINE)

TRIBUTARY DESIGN AREAS

DIAPHRAGM LEVEL	FLOOR-TO-FLOOR HEIGHT	SECTION	SECTION			sq ft
			A	O	B	
3	8 FT	Roof Surface	0	94	0	sq ft
			Wall surface	0	271	0
2	10 FT	Roof Surface	0	49	0	sq ft
			Wall surface	0	473	0
1	8 FT	Roof Surface	0	0	0	sq ft
			Wall surface	0	463	0
FND		Roof Surface	0	0	0	sq ft
			Wall surface	0	0	0

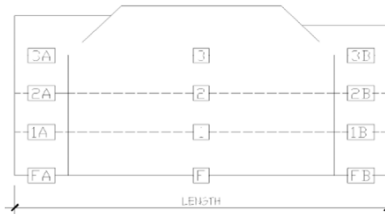

TRIBUTARY DESIGN LOADS: (0.6W)

SECTION	SECTION			kips
	A	O	B	
Story Shear	0.00	5.04	0.00	kips
	0.00	5.04	0.00	kips
Total Shear	5.04			kips
Story Shear	0.00	7.67	0.00	kips
	0.00	12.71	0.00	kips
Total Shear	12.71			kips
Story Shear	0.00	7.02	0.00	kips
	0.00	19.73	0.00	kips
Total Shear	19.73			kips
Story Shear	0.00	0.00	0.00	kips
	0.00	19.73	0.00	kips
Total Shear	19.73			kips

LONGITUDINAL DIRECTION (PARALLEL TO MAIN RIDGE LINE)

TRIBUTARY DESIGN AREAS

DIAPHRAGM LEVEL	FLOOR-TO-FLOOR HEIGHT	SECTION	SECTION			sq ft
			A	O	B	
3	8 FT	Roof Surface	0	118	0	sq ft
			Wall surface	0	180	0
2	10 FT	Roof Surface	0	151	0	sq ft
			Wall surface	0	438	0
1	8 FT	Roof Surface	0	0	0	sq ft
			Wall surface	0	364	0
FND		Roof Surface	0	0	0	sq ft
			Wall surface	0	0	0

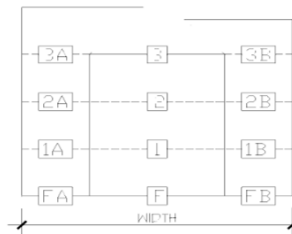

TRIBUTARY DESIGN LOADS: (0.6W)

SECTION	SECTION			kips
	A	O	B	
Story Shear	0.00	3.86	0.00	kips
	0.00	3.86	0.00	kips
Total Shear	3.86			kips
Story Shear	0.00	8.11	0.00	kips
	0.00	11.97	0.00	kips
Total Shear	11.97			kips
Story Shear	0.00	5.74	0.00	kips
	0.00	17.70	0.00	kips
Total Shear	17.70			kips
Story Shear	0.00	0.00	0.00	kips
	0.00	17.70	0.00	kips
Total Shear	17.70			kips



TRIS. LOAD CALCS:

- ALL RESULTANT LOCATIONS WERE DETERMINED BASED ON DISTANCE + MAGNITUDE OF LOAD FOR EA. SHEARWALL
- SOME RESULTANT FORCES ARE LESS THAN THE REQUIRED SUPPORT REACTIONS BASED ON A FLEXIBLE DIAPHRAGM. IT IS OUR PROFESSIONAL OPINION THAT THE MAGNITUDE OF THE PROVIDED LOADS ARE WITHIN AN ACCEPTABLE RANGE OF THESE REQ'D LOADS + THE TOTAL LOAD IS RESISTED BY THE SHEARWALLS SHOWN.

DIAPHRAGM CAPACITIES:

- UNSLOTTED DIAPHRAGM w 8d COMMON NAILS @ 6" o.c. EDGE NAILING + 2" MIN. NOMINAL FRAMING w/ 1/16" MIN. SHEATHING THICKNESS.

- MAX CAPACITY (CASE #1):

$$\frac{645 \text{ PLF} (0.92)}{2} = 297 \text{ PLF} \quad \frac{460 \text{ PLF} (0.92)}{2} = 212 \text{ PLF}$$

- MAX CAPACITY (CASE #2):

$$\frac{475 \text{ PLF} (0.92)}{2} = 218 \text{ PLF} \quad \frac{340 \text{ PLF} (0.92)}{2} = 156 \text{ PLF}$$

▲ = LOAD REQ'D PER FLEXIBLE DIAPHRAGM
■ = PROVIDED

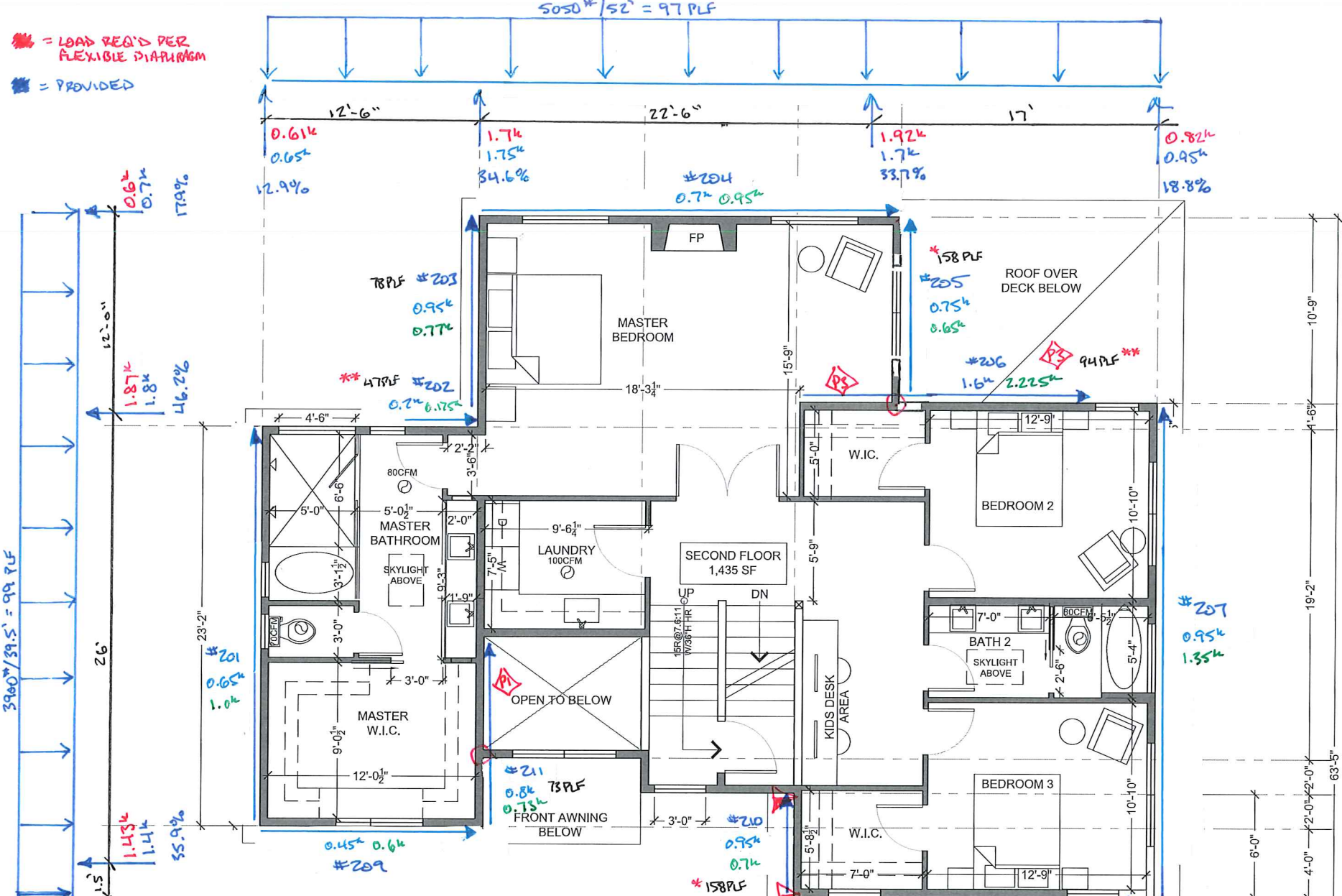

WIND DESIGN: EX. C NORMAL $K_{zt}=1.0$

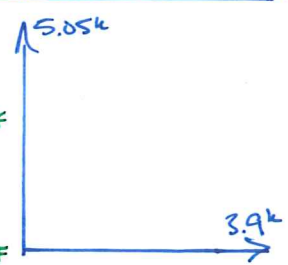

SEISMIC DESIGN:

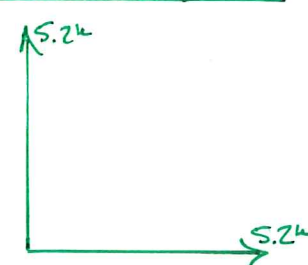

* SW #203 (78 PLF) + SW #211 (75 PLF) AS WELL AS SW #205 (158 PLF) + SW #210 (158 PLF) ARE WITHIN AN ACCEPTABLE TOLERANCE TO BE CONSIDERED PROPORTIONAL ALONG THEIR RESPECTIVE WALL LINES *

* SW #202 + SW #206 UNIT SHEARS COMPARED BASED ON SHEAR WALL CAPACITY:
 $\frac{P_1}{P_3} = \frac{336}{650} = 0.533$
 $94 (0.533) = 50 \text{ PLF}$
 47 PLF + 50 PLF ARE WITHIN AN ACCEPTABLE TOLERANCE TO BE CONSIDERED PROPORTIONAL. *

1 UPPER FLOOR PLAN

SCALE: 1/4" = 1'-0"

SUBMITTAL	
SD	9
DD	11

3440 97TH AVE
MERCER ISLAND, WA

DRAWING INFORMATION:
OWNER: MY BACKYARD, LLC

PROJECT#

DRAWING NAME:
ROOF PLAN



WIND DESIGN: EXP. C 110MPH

SEISMIC DESIGN:

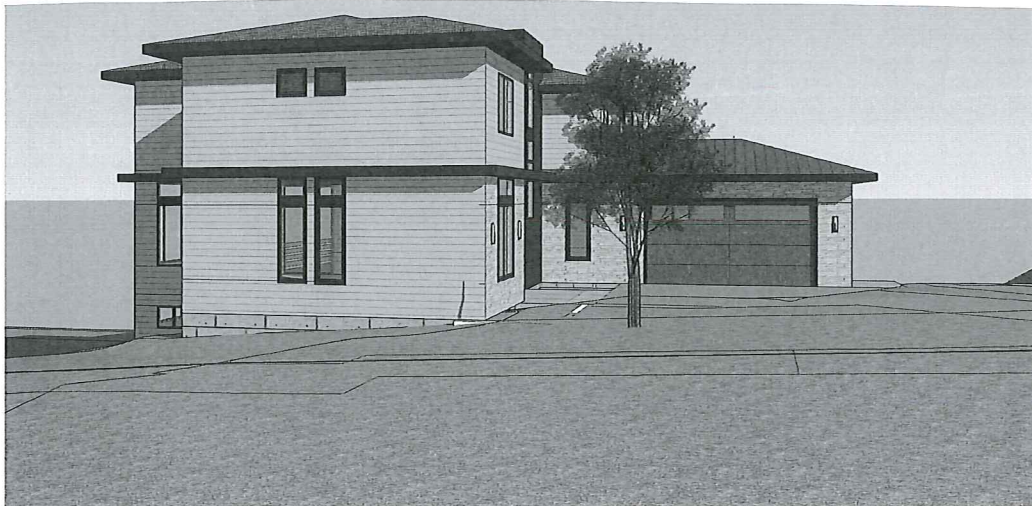
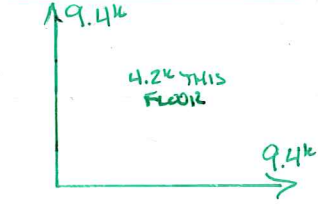
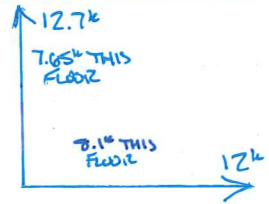

▲▲▲ = LOAD REQUIRED PER FLEXIBLE DIAPHRAGM
▲▲▲ = PROVIDED

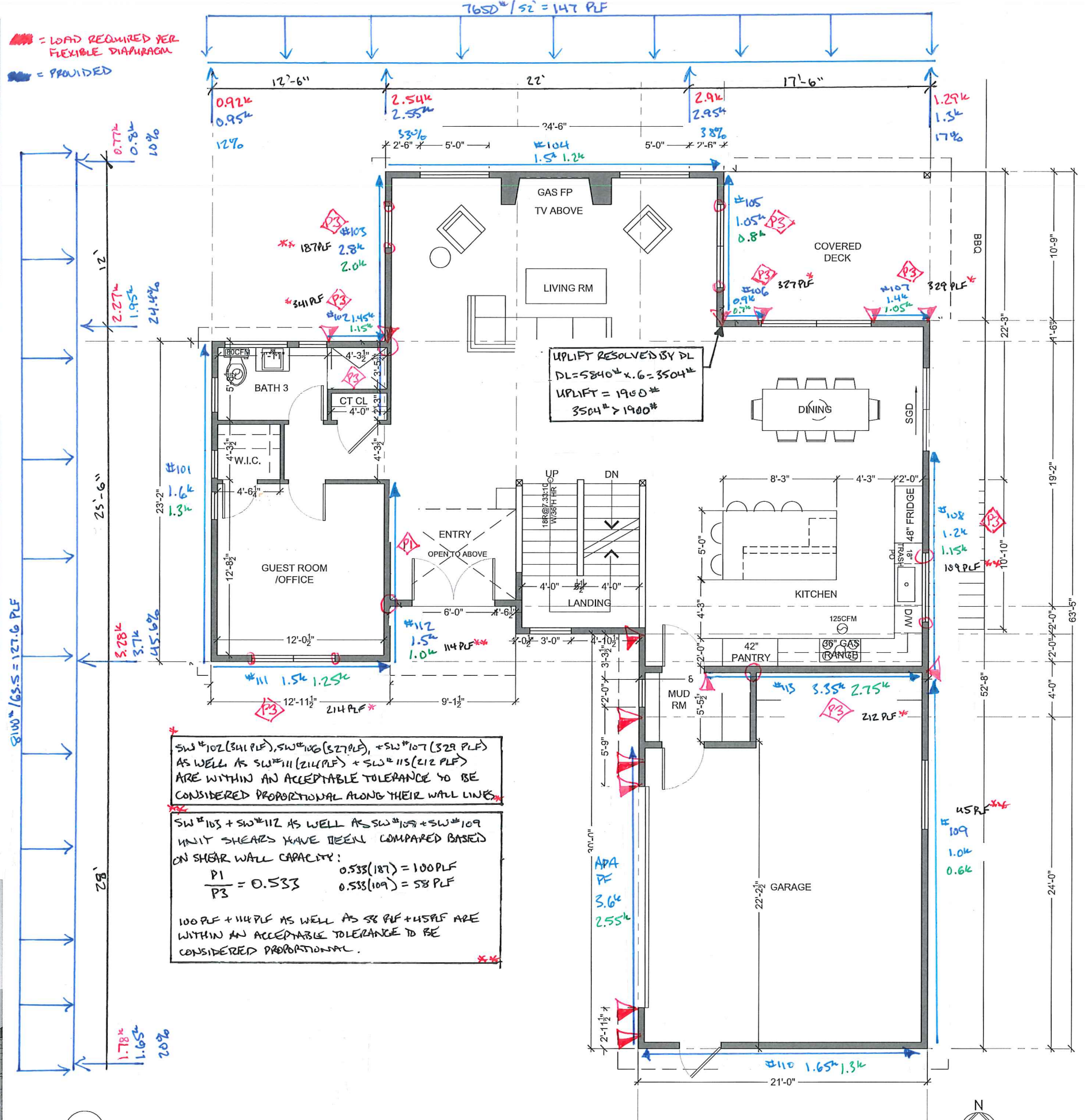

1 MAIN FLOOR PLAN

SCALE: 1/4" = 1'-0"



2425 SW ROXBUR
 SEATTLE, WA 981
 206.234.4411
 JACQUELINE
 JDESIGNSSEATTLE

SUBMITTAL	1
SD	9
DD	11

3440 97TH AVE
 MERCER ISLAND, WA

DRAWING INFORMATION
 OWNER:
 MY BACKYARD, LLC

PROJECT#

DRAWING NAME:
 FLOOR PL

A2.

SUBMITTAL	
SD	9
DD	11

3440 97TH AVE
MERCER ISLAND, WA

DRAWING INFORMA

OWNER:
MY BACKYARD, LLC

PROJECT#

DRAWING NAME:
FLOOR PL

A2.1

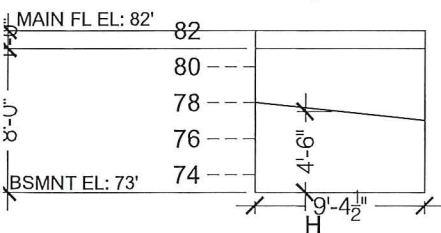
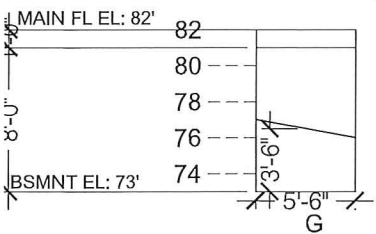
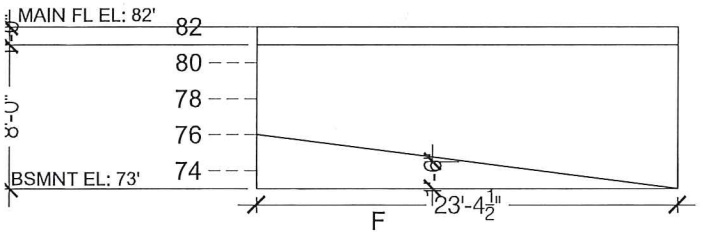
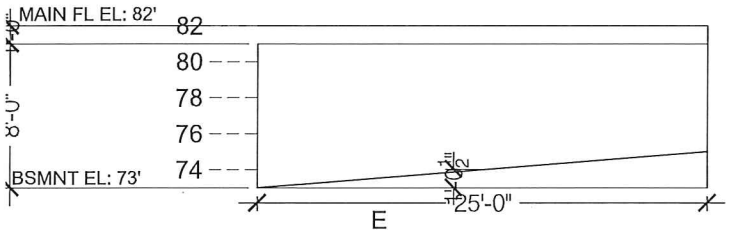
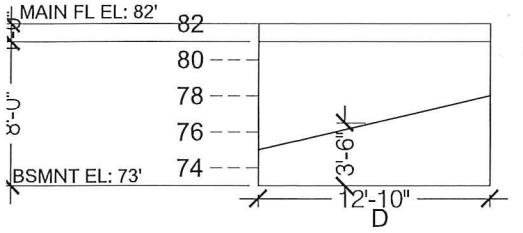
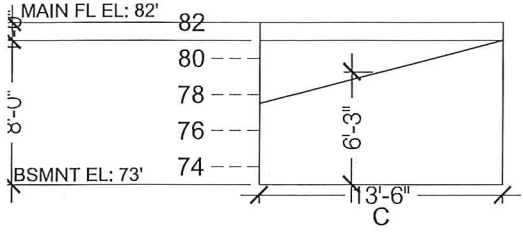
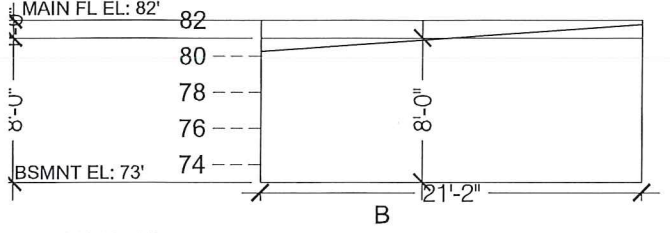
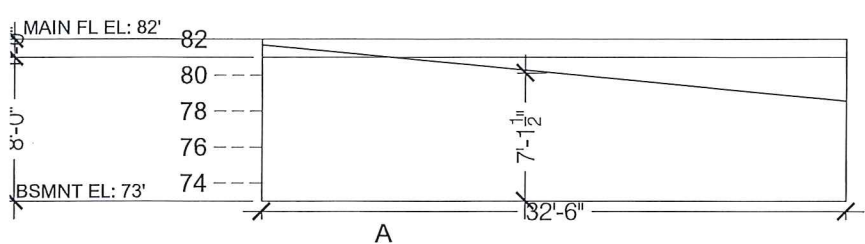

BASEMENT COVERAGE CALCS:

- A 32.5' 89% = 29'
- B 21' X 100% = 21'
- C 13.5' X 78% = 10.5'
- D 12.8 X 44% = 5.5'
- E 25' X 13% = 3'
- F 23' X 19% = 4.4'
- G 5.5 X 44% = 2.4'
- H 9.5 X 56% = 5.3'
- TOTALS 142.8', N/A, 81.1'

901 SF * 81.1' / 142.8' = 511.7 SF
EXCLUDED BASEMENT FLOOR AREA

LOAD REQUIRED PER FLEXIBLE DIAGRAM
PROVIDED

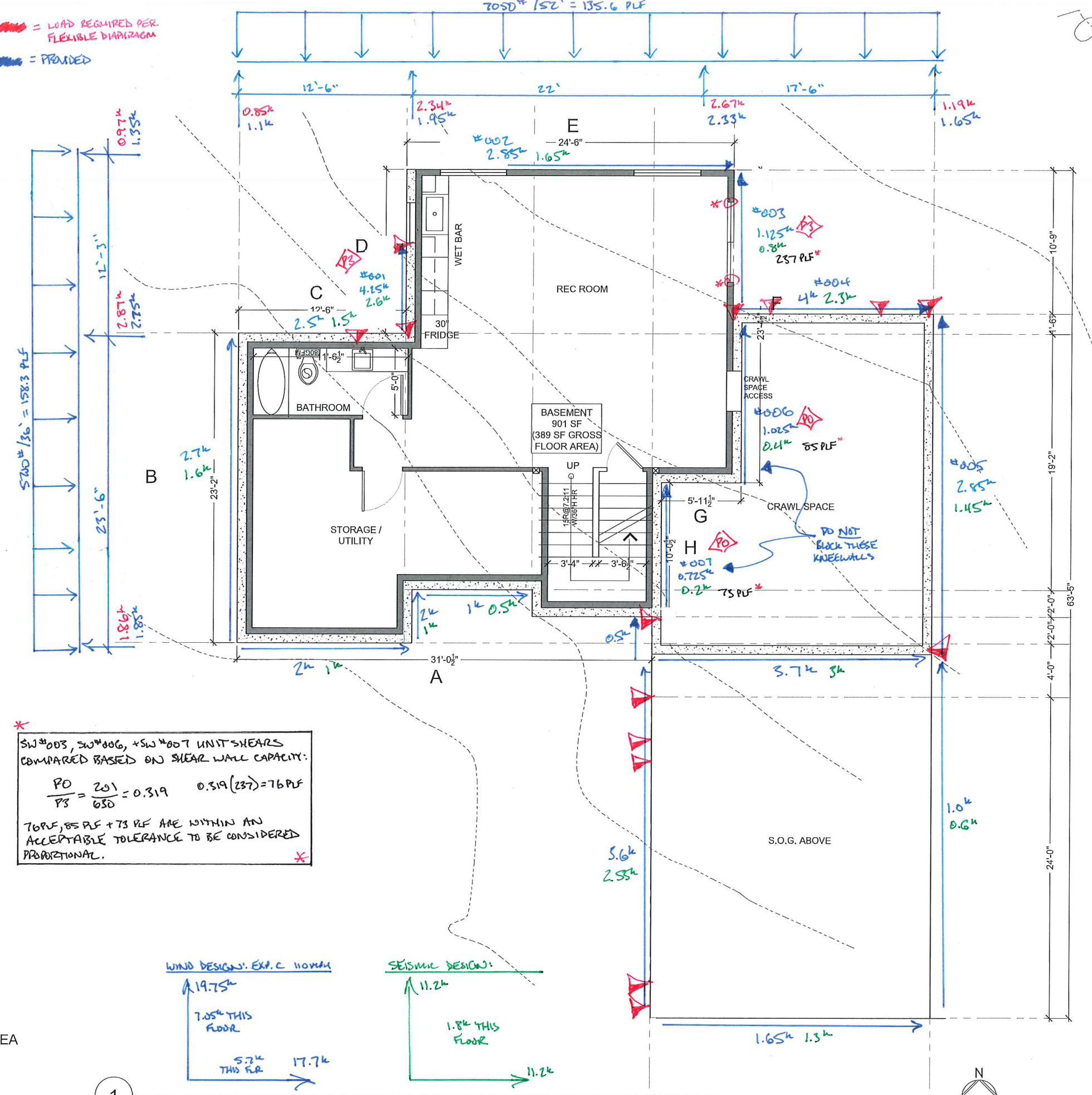

* SW#005, SW#006, +SW#007 UNIT SHEARS COMPARED BASED ON SHEAR WALL CAPACITY:
 $\frac{PO}{PS} = \frac{201}{630} = 0.319$ $0.319(237) = 76 \text{ PLF}$
TOP OF 85 PLF + 73 PLF ARE WITHIN AN ACCEPTABLE TOLERANCE TO BE CONSIDERED PROPORTIONAL.*

BSMNT WALL COVERAGE DIAGRAMS

1 BASEMENT PLAN

SCALE: 1/4" = 1'-0"



SHEARWALL DESIGN SUMMARY

SHEARWALL 201: 2ND - SIDE EXT. WALL OF MASTER WIC/MAST BD

SHEARWALL PROPERTIES:

WALL HEIGHT, H	<input type="text" value="8.0"/>	FT.	MAX WALL OPENING HT, H _c	<input type="text" value="1.5"/>	FT.	SHEARWALL ASSEMBLY	<input type="text" value="P1"/>
WALL LENGTH, L	<input type="text" value="23.2"/>	FT.	QUALIFYING WALL LENGTH, L	<input type="text" value="18.2"/>	FT.		

CAPACITY EVALUATION:

TOTAL SHEAR LOAD ON WALL	<input type="text" value="650"/>	LBS	<	ALLOWABLE SHEARWALL CAPACITY	<input type="text" value="6102"/>	LBS
--------------------------	----------------------------------	-----	---	------------------------------	-----------------------------------	-----

SHEARWALL ASSEMBLY SPECIFICATION

P1 - 1-SIDE 7/16" OSB
FASTENED W/ 8D NAILS AT 6"D.C. PANEL EDGES & 12"D.C. PANEL FIELD - EDGES BLOCKED
ADEQUATE

OVERTURNING EVALUATION:

RESISTIVE DL	<input type="text" value="134"/>	PLF	OVERTURNING MOMENT	<input type="text" value="5.2"/>	K-FT	HOLD DOWN DESIGN LOAD	<input type="text" value="0"/>	LBS
DL AT ENDS OF WALL	<input type="text" value="100"/>	LBS	RESISTIVE MOMENT	<input type="text" value="23.0"/>	K-FT	HOLD DOWN CAPACITY	<input type="text" value="0"/>	LBS

HOLD-DOWN SPECIFICATION

NO HOLD DOWN REQUIRED

SHEARWALL 202: 2ND - REAR EXT. WALL OF MASTER BATH

SHEARWALL PROPERTIES:

WALL HEIGHT, H	<input type="text" value="8.0"/>	FT.	MAX WALL OPENING HT, H _c	<input type="text" value="0.0"/>	FT.	SHEARWALL ASSEMBLY	<input type="text" value="P1"/>
WALL LENGTH, L	<input type="text" value="4.3"/>	FT.	QUALIFYING WALL LENGTH, L	<input type="text" value="4.3"/>	FT.		

CAPACITY EVALUATION:

TOTAL SHEAR LOAD ON WALL	<input type="text" value="200"/>	LBS	<	ALLOWABLE SHEARWALL CAPACITY	<input type="text" value="1428"/>	LBS
--------------------------	----------------------------------	-----	---	------------------------------	-----------------------------------	-----

SHEARWALL ASSEMBLY SPECIFICATION

P1 - 1-SIDE 7/16" OSB
FASTENED W/ 8D NAILS AT 6"D.C. PANEL EDGES & 12"D.C. PANEL FIELD - EDGES BLOCKED
ADEQUATE

OVERTURNING EVALUATION:

RESISTIVE DL	<input type="text" value="260"/>	PLF	OVERTURNING MOMENT	<input type="text" value="1.6"/>	K-FT	HOLD DOWN DESIGN LOAD	<input type="text" value="0"/>	LBS
DL AT ENDS OF WALL	<input type="text" value="195"/>	LBS	RESISTIVE MOMENT	<input type="text" value="1.9"/>	K-FT	HOLD DOWN CAPACITY	<input type="text" value="0"/>	LBS

HOLD-DOWN SPECIFICATION

NO HOLD DOWN REQUIRED



SHEARWALL DESIGN SUMMARY

SHEARWALL 203: 2ND - SIDE EXT. WALL OF MASTER BD BY BATH

SHEARWALL PROPERTIES:

WALL HEIGHT, H	<input type="text" value="8.0"/>	FT.	MAX WALL OPENING HT, H _c	<input type="text" value="0.0"/>	FT.	SHEARWALL ASSEMBLY	<input type="text" value="P1"/>
WALL LENGTH, L	<input type="text" value="12.3"/>	FT.	QUALIFYING WALL LENGTH, L	<input type="text" value="12.3"/>	FT.		

CAPACITY EVALUATION:

TOTAL SHEAR LOAD ON WALL	<input type="text" value="950"/>	LBS	<	ALLOWABLE SHEARWALL CAPACITY	<input type="text" value="4116"/>	LBS
--------------------------	----------------------------------	-----	---	------------------------------	-----------------------------------	-----

SHEARWALL ASSEMBLY SPECIFICATION

P1 - 1-SIDE 7/16" OSB
FASTENED W/ BD NAILS AT 6"D.C. PANEL EDGES & 12"D.C. PANEL FIELD - EDGES BLOCKED
ADEQUATE

OVERTURNING EVALUATION:

RESISTIVE DL	<input type="text" value="134"/>	PLF	OVERTURNING MOMENT	<input type="text" value="7.6"/>	K-FT	UPLIFT CONNECTOR DESIGN LOAD	<input type="text" value="0"/>	LBS
DL AT ENDS OF WALL	<input type="text" value="250"/>	LBS	RESISTIVE MOMENT	<input type="text" value="7.9"/>	K-FT	HOLDOWN CAPACITY	<input type="text" value="0"/>	LBS

HOLD-DOWN SPECIFICATION

NO HOLDOWN REQUIRED

SHEARWALL 204: 2ND - REAR EXT. WALL OF MASTER BD

SHEARWALL PROPERTIES:

WALL HEIGHT, H	<input type="text" value="8.0"/>	FT.	MAX WALL OPENING HT, H _c	<input type="text" value="4.0"/>	FT.	SHEARWALL ASSEMBLY	<input type="text" value="P1"/>
WALL LENGTH, L	<input type="text" value="24.5"/>	FT.	QUALIFYING WALL LENGTH, L	<input type="text" value="14.5"/>	FT.		

CAPACITY EVALUATION:

TOTAL SHEAR LOAD ON WALL	<input type="text" value="700"/>	LBS	<	ALLOWABLE SHEARWALL CAPACITY	<input type="text" value="4116"/>	LBS
--------------------------	----------------------------------	-----	---	------------------------------	-----------------------------------	-----

SHEARWALL ASSEMBLY SPECIFICATION

P1 - 1-SIDE 7/16" OSB
FASTENED W/ BD NAILS AT 6"D.C. PANEL EDGES & 12"D.C. PANEL FIELD - EDGES BLOCKED
ADEQUATE

OVERTURNING EVALUATION:

RESISTIVE DL	<input type="text" value="215"/>	PLF	OVERTURNING MOMENT	<input type="text" value="5.6"/>	K-FT	HOLD DOWN DESIGN LOAD	<input type="text" value="0"/>	LBS
DL AT ENDS OF WALL	<input type="text" value="200"/>	LBS	RESISTIVE MOMENT	<input type="text" value="41.7"/>	K-FT	HOLDOWN CAPACITY	<input type="text" value="0"/>	LBS

HOLD-DOWN SPECIFICATION

NO HOLDOWN REQUIRED



SHEARWALL DESIGN SUMMARY

SHEARWALL 205: 2ND - SIDE EXT. WALL OF MAST BD BY WIG

SHEARWALL PROPERTIES:

WALL HEIGHT, H	<input type="text" value="8.0"/>	FT.	MAX WALL OPENING HT, H _c	<input type="text" value="4.0"/>	FT.	SHEARWALL ASSEMBLY	<input type="text" value="P1"/>
WALL LENGTH, L	<input type="text" value="10.8"/>	FT.	QUALIFYING WALL LENGTH, L	<input type="text" value="4.8"/>	FT.		

CAPACITY EVALUATION:

TOTAL SHEAR LOAD ON WALL	<input type="text" value="750"/>	LBS	<	ALLOWABLE SHEARWALL CAPACITY	<input type="text" value="1596"/>	LBS
--------------------------	----------------------------------	-----	---	------------------------------	-----------------------------------	-----

SHEARWALL ASSEMBLY SPECIFICATION

P1 - 1-SIDE 7/16" OSB
FASTENED W/ BD NAILS AT 6"D.C. PANEL EDGES & 12"D.C. PANEL FIELD - EDGES BLOCKED
ADEQUATE

OVERTURNING EVALUATION:

RESISTIVE DL	<input type="text" value="134"/>	PLF	OVERTURNING MOMENT	<input type="text" value="6.0"/>	K-FT	UPLIFT CONNECTOR DESIGN LOAD	<input type="text" value="0"/>	LBS
DL AT ENDS OF WALL	<input type="text" value="335"/>	LBS	RESISTIVE MOMENT	<input type="text" value="6.8"/>	K-FT	HOLDOWN CAPACITY	<input type="text" value="0"/>	LBS

HOLD-DOWN SPECIFICATION

NO HOLDOWN REQUIRED

SHEARWALL 206: 2ND - REAR EXT. WALL OF BD#2

SHEARWALL PROPERTIES:

WALL HEIGHT, H	<input type="text" value="8.0"/>	FT.	MAX WALL OPENING HT, H _c	<input type="text" value="0.0"/>	FT.	SHEARWALL ASSEMBLY	<input type="text" value="P3"/>
WALL LENGTH, L	<input type="text" value="17.0"/>	FT.	QUALIFYING WALL LENGTH, L	<input type="text" value="17.0"/>	FT.		

CAPACITY EVALUATION:

TOTAL SHEAR LOAD ON WALL	<input type="text" value="1600"/>	LBS	<	ALLOWABLE SHEARWALL CAPACITY	<input type="text" value="10710"/>	LBS
--------------------------	-----------------------------------	-----	---	------------------------------	------------------------------------	-----

SHEARWALL ASSEMBLY SPECIFICATION

P3 - 1-SIDE 7/16" OSB
FASTENED W/ BD NAILS AT 3"D.C. PANEL EDGES & 12"D.C. PANEL FIELD - EDGES BLOCKED
ADEQUATE

OVERTURNING EVALUATION:

RESISTIVE DL	<input type="text" value="340"/>	PLF	OVERTURNING MOMENT	<input type="text" value="12.8"/>	K-FT	HOLD DOWN DESIGN LOAD	<input type="text" value="0"/>	LBS
DL AT ENDS OF WALL	<input type="text" value="0"/>	LBS	RESISTIVE MOMENT	<input type="text" value="29.5"/>	K-FT	HOLDOWN CAPACITY	<input type="text" value="0"/>	LBS

HOLD-DOWN SPECIFICATION

NO HOLDOWN REQUIRED



SHEARWALL DESIGN SUMMARY

SHEARWALL 207: 2ND - SIDE EXT. WALL OF BD#2 / BD#3

SHEARWALL PROPERTIES:

WALL HEIGHT, H	<input type="text" value="8.0"/>	FT.	MAX WALL OPENING HT, H _c	<input type="text" value="4.0"/>	FT.	SHEARWALL ASSEMBLY	<input type="text" value="P1"/>
WALL LENGTH, L	<input type="text" value="28.7"/>	FT.	QUALIFYING WALL LENGTH, L	<input type="text" value="12.7"/>	FT.		

CAPACITY EVALUATION:

TOTAL SHEAR LOAD ON WALL	<input type="text" value="950"/>	LBS	<	ALLOWABLE SHEARWALL CAPACITY	<input type="text" value="4257"/>	LBS
--------------------------	----------------------------------	-----	---	------------------------------	-----------------------------------	-----

SHEARWALL ASSEMBLY SPECIFICATION

P1 - 1-SIDE 7/16" OSB
FASTENED W/ BD NAILS AT 6"D.C. PANEL EDGES & 12"D.C. PANEL FIELD - EDGES BLOCKED
ADEQUATE

OVERTURNING EVALUATION:

RESISTIVE DL	<input type="text" value="134"/>	PLF	OVERTURNING MOMENT	<input type="text" value="7.6"/>	K-FT	UPLIFT CONNECTOR DESIGN LOAD	<input type="text" value="0"/>	LBS
DL AT ENDS OF WALL	<input type="text" value="200"/>	LBS	RESISTIVE MOMENT	<input type="text" value="36.5"/>	K-FT	HOLDOWN CAPACITY	<input type="text" value="0"/>	LBS

HOLD-DOWN SPECIFICATION

NO HOLDOWN REQUIRED

SHEARWALL 208: 2ND - FRONT EXT. WALL OF BD#3

SHEARWALL PROPERTIES:

WALL HEIGHT, H	<input type="text" value="8.0"/>	FT.	MAX WALL OPENING HT, H _c	<input type="text" value="1.7"/>	FT.	SHEARWALL ASSEMBLY	<input type="text" value="P1"/>
WALL LENGTH, L	<input type="text" value="21.0"/>	FT.	QUALIFYING WALL LENGTH, L	<input type="text" value="15.0"/>	FT.		

CAPACITY EVALUATION:

TOTAL SHEAR LOAD ON WALL	<input type="text" value="950"/>	LBS	<	ALLOWABLE SHEARWALL CAPACITY	<input type="text" value="5040"/>	LBS
--------------------------	----------------------------------	-----	---	------------------------------	-----------------------------------	-----

SHEARWALL ASSEMBLY SPECIFICATION

P1 - 1-SIDE 7/16" OSB
FASTENED W/ BD NAILS AT 6"D.C. PANEL EDGES & 12"D.C. PANEL FIELD - EDGES BLOCKED
ADEQUATE

OVERTURNING EVALUATION:

RESISTIVE DL	<input type="text" value="340"/>	PLF	OVERTURNING MOMENT	<input type="text" value="7.6"/>	K-FT	HOLD DOWN DESIGN LOAD	<input type="text" value="0"/>	LBS
DL AT ENDS OF WALL	<input type="text" value="200"/>	LBS	RESISTIVE MOMENT	<input type="text" value="47.5"/>	K-FT	HOLDOWN CAPACITY	<input type="text" value="0"/>	LBS

HOLD-DOWN SPECIFICATION

NO HOLDOWN REQUIRED



SHEARWALL DESIGN SUMMARY

SHEARWALL 209: 2ND - FRONT EXT. WALL OF MASTER WIC

SHEARWALL PROPERTIES:

WALL HEIGHT, H	<input type="text" value="8.0"/>	FT.	MAX WALL OPENING HT, H _c	<input type="text" value="4.0"/>	FT.	SHEARWALL ASSEMBLY	<input type="text" value="P1"/>
WALL LENGTH, L	<input type="text" value="13.0"/>	FT.	QUALIFYING WALL LENGTH, L	<input type="text" value="7.0"/>	FT.		

CAPACITY EVALUATION:

TOTAL SHEAR LOAD ON WALL	<input type="text" value="450"/>	LBS	<	ALLOWABLE SHEARWALL CAPACITY	<input type="text" value="2184"/>	LBS
--------------------------	----------------------------------	-----	---	------------------------------	-----------------------------------	-----

SHEARWALL ASSEMBLY SPECIFICATION

P1 - 1-SIDE 7/16" OSB
FASTENED W/ 8D NAILS AT 6"D.C. PANEL EDGES & 12"D.C. PANEL FIELD - EDGES BLOCKED
ADEQUATE

OVERTURNING EVALUATION:

RESISTIVE DL	<input type="text" value="260"/>	PLF	OVERTURNING MOMENT	<input type="text" value="3.6"/>	K-FT	UPLIFT CONNECTOR DESIGN LOAD	<input type="text" value="0"/>	LBS
DL AT ENDS OF WALL	<input type="text" value="535"/>	LBS	RESISTIVE MOMENT	<input type="text" value="17.4"/>	K-FT	HOLDOWN CAPACITY	<input type="text" value="0"/>	LBS

HOLD-DOWN SPECIFICATION

NO HOLDOWN REQUIRED

SHEARWALL 210: 2ND - SIDE EXT. WALL OF BD#3 WIC

SHEARWALL PROPERTIES:

WALL HEIGHT, H	<input type="text" value="8.0"/>	FT.	MAX WALL OPENING HT, H _c	<input type="text" value="0.0"/>	FT.	SHEARWALL ASSEMBLY	<input type="text" value="P1"/>
WALL LENGTH, L	<input type="text" value="6.0"/>	FT.	QUALIFYING WALL LENGTH, L	<input type="text" value="6.0"/>	FT.		

CAPACITY EVALUATION:

TOTAL SHEAR LOAD ON WALL	<input type="text" value="950"/>	LBS	<	ALLOWABLE SHEARWALL CAPACITY	<input type="text" value="2016"/>	LBS
--------------------------	----------------------------------	-----	---	------------------------------	-----------------------------------	-----

SHEARWALL ASSEMBLY SPECIFICATION

P1 - 1-SIDE 7/16" OSB
FASTENED W/ 8D NAILS AT 6"D.C. PANEL EDGES & 12"D.C. PANEL FIELD - EDGES BLOCKED
ADEQUATE

OVERTURNING EVALUATION:

RESISTIVE DL	<input type="text" value="134"/>	PLF	OVERTURNING MOMENT	<input type="text" value="7.6"/>	K-FT	HOLD DOWN DESIGN LOAD	<input type="text" value="865"/>	LBS
DL AT ENDS OF WALL	<input type="text" value="268"/>	LBS	RESISTIVE MOMENT	<input type="text" value="2.4"/>	K-FT	HOLDOWN CAPACITY	<input type="text" value="1705"/>	LBS

HOLD-DOWN SPECIFICATION

SIMPSON CS16 STRAP TIE (14" END LENGTH)
FASTENED W/ 26-8D NAILS



SHEARWALL DESIGN SUMMARY

SHEARWALL 211: 2ND - SIDE EXT. WALL OF MAST WIG BY ENTRY

SHEARWALL PROPERTIES:

WALL HEIGHT, H	<input type="text" value="8.0"/>	FT.	MAX WALL OPENING HT, H _c	<input type="text" value="0.0"/>	FT.	SHEARWALL ASSEMBLY	<input type="text" value="P1"/>
WALL LENGTH, L	<input type="text" value="11.0"/>	FT.	QUALIFYING WALL LENGTH, L	<input type="text" value="11.0"/>	FT.		

CAPACITY EVALUATION:

TOTAL SHEAR LOAD ON WALL	<input type="text" value="800"/>	LBS	<	ALLOWABLE SHEARWALL CAPACITY	<input type="text" value="3696"/>	LBS
--------------------------	----------------------------------	-----	---	------------------------------	-----------------------------------	-----

SHEARWALL ASSEMBLY SPECIFICATION

P1 - 1-SIDE 7/16" OSB
FASTENED W/ 8D NAILS AT 6"O.C. PANEL EDGES & 12"O.C. PANEL FIELD - EDGES BLOCKED
ADEQUATE

OVERTURNING EVALUATION:

RESISTIVE DL	<input type="text" value="134"/>	PLF	OVERTURNING MOMENT	<input type="text" value="6.4"/>	K-FT	UPLIFT CONNECTOR DESIGN LOAD	<input type="text" value="0"/>	LBS
DL AT ENDS OF WALL	<input type="text" value="400"/>	LBS	RESISTIVE MOMENT	<input type="text" value="7.5"/>	K-FT	HOLDOWN CAPACITY	<input type="text" value="0"/>	LBS

HOLD-DOWN SPECIFICATION

NO HOLDOWN REQUIRED

SHEARWALL XXX: - NOT USED

SHEARWALL PROPERTIES:

WALL HEIGHT, H	<input type="text" value="0.0"/>	FT.	MAX WALL OPENING HT, H _c	<input type="text" value="0.0"/>	FT.	SHEARWALL ASSEMBLY	<input type="text" value="PO"/>
WALL LENGTH, L	<input type="text" value="0.0"/>	FT.	QUALIFYING WALL LENGTH, L	<input type="text" value="0.0"/>	FT.		

CAPACITY EVALUATION:

TOTAL SHEAR LOAD ON WALL	<input type="text" value="0"/>	LBS	#####	ALLOWABLE SHEARWALL CAPACITY	<input type="text" value="#DIV/0!"/>	LBS
--------------------------	--------------------------------	-----	-------	------------------------------	--------------------------------------	-----

SHEARWALL ASSEMBLY SPECIFICATION

PO - 1-SIDE 7/16" OSB
FASTENED W/ 8D NAILS AT 6"O.C. PANEL EDGES & 12"O.C. PANEL FIELD - UNBLOCKED
#DIV/0!

OVERTURNING EVALUATION:

RESISTIVE DL	<input type="text" value="0"/>	PLF	OVERTURNING MOMENT	<input type="text" value="#DIV/0!"/>	K-FT	HOLD DOWN DESIGN LOAD	<input type="text" value="0"/>	LBS
DL AT ENDS OF WALL	<input type="text" value="0"/>	LBS	RESISTIVE MOMENT	<input type="text" value="0.0"/>	K-FT	HOLDOWN CAPACITY	<input type="text" value="0"/>	LBS

HOLD-DOWN SPECIFICATION

NO HOLDOWN REQUIRED



SHEARWALL DESIGN SUMMARY

SHEARWALL 101: 1ST - SIDE EXT. WALL OF GUEST ROOM/BATH #3

SHEARWALL PROPERTIES:

WALL HEIGHT, H	<input type="text" value="10.0"/>	FT.	MAX WALL OPENING HT, H _c	<input type="text" value="6.5"/>	FT.	SHEARWALL ASSEMBLY	<input type="text" value="P1"/>
WALL LENGTH, L	<input type="text" value="23.2"/>	FT.	QUALIFYING WALL LENGTH, L	<input type="text" value="18.2"/>	FT.		

CAPACITY EVALUATION:

TOTAL SHEAR LOAD ON WALL	<input type="text" value="1600"/>	LBS	<	ALLOWABLE SHEARWALL CAPACITY	<input type="text" value="2724"/>	LBS
--------------------------	-----------------------------------	-----	---	------------------------------	-----------------------------------	-----

SHEARWALL ASSEMBLY SPECIFICATION

P1 - 1-SIDE 7/16" OSB
FASTENED W/ 8D NAILS AT 6"D.C. PANEL EDGES & 12"D.C. PANEL FIELD - EDGES BLOCKED
ADEQUATE

OVERTURNING EVALUATION:

RESISTIVE DL	<input type="text" value="234"/>	PLF	OVERTURNING MOMENT	<input type="text" value="16.0"/>	K-FT	UPLIFT CONNECTOR DESIGN LOAD	<input type="text" value="0"/>	LBS
DL AT ENDS OF WALL	<input type="text" value="370"/>	LBS	RESISTIVE MOMENT	<input type="text" value="42.8"/>	K-FT	HOLDOWN CAPACITY	<input type="text" value="0"/>	LBS

HOLD-DOWN SPECIFICATION

NO HOLDOWN REQUIRED

SHEARWALL 102: 1ST - REAR EXT. WALL OF BATH #3

SHEARWALL PROPERTIES:

WALL HEIGHT, H	<input type="text" value="10.0"/>	FT.	MAX WALL OPENING HT, H _c	<input type="text" value="0.0"/>	FT.	SHEARWALL ASSEMBLY	<input type="text" value="P3"/>
WALL LENGTH, L	<input type="text" value="4.3"/>	FT.	QUALIFYING WALL LENGTH, L	<input type="text" value="4.3"/>	FT.		

CAPACITY EVALUATION:

TOTAL SHEAR LOAD ON WALL	<input type="text" value="1450"/>	LBS	<	ALLOWABLE SHEARWALL CAPACITY	<input type="text" value="2559"/>	LBS
--------------------------	-----------------------------------	-----	---	------------------------------	-----------------------------------	-----

SHEARWALL ASSEMBLY SPECIFICATION

P3 - 1-SIDE 7/16" OSB
FASTENED W/ 8D NAILS AT 3"D.C. PANEL EDGES & 12"D.C. PANEL FIELD - EDGES BLOCKED
ADEQUATE

OVERTURNING EVALUATION:

RESISTIVE DL	<input type="text" value="410"/>	PLF	OVERTURNING MOMENT	<input type="text" value="14.5"/>	K-FT	HOLD DOWN DESIGN LOAD	<input type="text" value="2739"/>	LBS
DL AT ENDS OF WALL	<input type="text" value="250"/>	LBS	RESISTIVE MOMENT	<input type="text" value="2.9"/>	K-FT	HOLDOWN CAPACITY	<input type="text" value="3105"/>	LBS

HOLD-DOWN SPECIFICATION

SIMPSON HTT4 HOLDOWN
FASTENED W/ 18-10D NAILS W/ 5/8" DIA. ALL-THREAD ROD



SHEARWALL DESIGN SUMMARY

SHEARWALL 103: 1ST - SIDE EXT. WALL OF LIVING ROOM

SHEARWALL PROPERTIES:

WALL HEIGHT, H	<input type="text" value="10.0"/>	FT.	MAX WALL OPENING HT, H _c	<input type="text" value="7.5"/>	FT.	SHEARWALL ASSEMBLY	<input type="text" value="P3"/>
WALL LENGTH, L	<input type="text" value="18.0"/>	FT.	QUALIFYING WALL LENGTH, L	<input type="text" value="15.0"/>	FT.		

CAPACITY EVALUATION:

TOTAL SHEAR LOAD ON WALL	<input type="text" value="2800"/>	LBS	<	ALLOWABLE SHEARWALL CAPACITY	<input type="text" value="2835"/>	LBS
--------------------------	-----------------------------------	-----	---	------------------------------	-----------------------------------	-----

SHEARWALL ASSEMBLY SPECIFICATION

P3 - 1-SIDE 7/16" OSB
FASTENED W/ 8D NAILS AT 3"D.C. PANEL EDGES & 12"D.C. PANEL FIELD - EDGES BLOCKED
ADEQUATE

OVERTURNING EVALUATION:

RESISTIVE DL	<input type="text" value="234"/>	PLF	OVERTURNING MOMENT	<input type="text" value="28.0"/>	K-FT	UPLIFT CONNECTOR DESIGN LOAD	<input type="text" value="0"/>	LBS
DL AT ENDS OF WALL	<input type="text" value="700"/>	LBS	RESISTIVE MOMENT	<input type="text" value="30.3"/>	K-FT	HOLDOWN CAPACITY	<input type="text" value="0"/>	LBS

HOLD-DOWN SPECIFICATION

NO HOLDOWN REQUIRED

SHEARWALL 104: 1ST - REAR EXT. WALL OF LIVING ROOM

SHEARWALL PROPERTIES:

WALL HEIGHT, H	<input type="text" value="10.0"/>	FT.	MAX WALL OPENING HT, H _c	<input type="text" value="7.5"/>	FT.	SHEARWALL ASSEMBLY	<input type="text" value="P1"/>
WALL LENGTH, L	<input type="text" value="24.5"/>	FT.	QUALIFYING WALL LENGTH, L	<input type="text" value="14.5"/>	FT.		

CAPACITY EVALUATION:

TOTAL SHEAR LOAD ON WALL	<input type="text" value="1500"/>	LBS	<	ALLOWABLE SHEARWALL CAPACITY	<input type="text" value="2058"/>	LBS
--------------------------	-----------------------------------	-----	---	------------------------------	-----------------------------------	-----

SHEARWALL ASSEMBLY SPECIFICATION

P1 - 1-SIDE 7/16" OSB
FASTENED W/ 8D NAILS AT 6"D.C. PANEL EDGES & 12"D.C. PANEL FIELD - EDGES BLOCKED
ADEQUATE

OVERTURNING EVALUATION:

RESISTIVE DL	<input type="text" value="365"/>	PLF	OVERTURNING MOMENT	<input type="text" value="15.0"/>	K-FT	HOLD DOWN DESIGN LOAD	<input type="text" value="0"/>	LBS
DL AT ENDS OF WALL	<input type="text" value="400"/>	LBS	RESISTIVE MOMENT	<input type="text" value="71.6"/>	K-FT	HOLDOWN CAPACITY	<input type="text" value="0"/>	LBS

HOLD-DOWN SPECIFICATION

NO HOLDOWN REQUIRED



SHEARWALL DESIGN SUMMARY

SHEARWALL 105: 1ST - SIDE EXT. WALL OF LIVING ROOM BY COV DECK

SHEARWALL PROPERTIES:

WALL HEIGHT, H	<input type="text" value="10.0"/>	FT.	MAX WALL OPENING HT, H _c	<input type="text" value="7.5"/>	FT.	SHEARWALL ASSEMBLY	<input type="text" value="P3"/>
WALL LENGTH, L	<input type="text" value="10.8"/>	FT.	QUALIFYING WALL LENGTH, L	<input type="text" value="4.8"/>	FT.		

CAPACITY EVALUATION:

TOTAL SHEAR LOAD ON WALL	<input type="text" value="1050"/>	LBS	<	ALLOWABLE SHEARWALL CAPACITY	<input type="text" value="1693"/>	LBS
--------------------------	-----------------------------------	-----	---	------------------------------	-----------------------------------	-----

SHEARWALL ASSEMBLY SPECIFICATION

P3 - 1-SIDE 7/16" OSB
FASTENED W/ 8D NAILS AT 3"D.C. PANEL EDGES & 12"D.C. PANEL FIELD - EDGES BLOCKED
ADEQUATE

OVERTURNING EVALUATION:

RESISTIVE DL	<input type="text" value="234"/>	PLF	OVERTURNING MOMENT	<input type="text" value="10.5"/>	K-FT	UPLIFT CONNECTOR DESIGN LOAD	<input type="text" value="0"/>	LBS
DL AT ENDS OF WALL	<input type="text" value="1700"/>	LBS	RESISTIVE MOMENT	<input type="text" value="19.1"/>	K-FT	HOLDOWN CAPACITY	<input type="text" value="0"/>	LBS

HOLD-DOWN SPECIFICATION

NO HOLDOWN REQUIRED

SHEARWALL 106: 1ST - REAR EXT. WALL OF DINING ROOM

SHEARWALL PROPERTIES:

WALL HEIGHT, H	<input type="text" value="10.0"/>	FT.	MAX WALL OPENING HT, H _c	<input type="text" value="0.0"/>	FT.	SHEARWALL ASSEMBLY	<input type="text" value="P3"/>
WALL LENGTH, L	<input type="text" value="2.8"/>	FT.	QUALIFYING WALL LENGTH, L	<input type="text" value="2.8"/>	FT.		

CAPACITY EVALUATION:

TOTAL SHEAR LOAD ON WALL	<input type="text" value="900"/>	LBS	<	ALLOWABLE SHEARWALL CAPACITY	<input type="text" value="1408"/>	LBS
--------------------------	----------------------------------	-----	---	------------------------------	-----------------------------------	-----

SHEARWALL ASSEMBLY SPECIFICATION

P3 - 1-SIDE 7/16" OSB
FASTENED W/ 8D NAILS AT 3"D.C. PANEL EDGES & 12"D.C. PANEL FIELD - EDGES BLOCKED
ADEQUATE

OVERTURNING EVALUATION:

RESISTIVE DL	<input type="text" value="575"/>	PLF	OVERTURNING MOMENT	<input type="text" value="9.0"/>	K-FT	HOLD DOWN DESIGN LOAD	<input type="text" value="1898"/>	LBS
DL AT ENDS OF WALL	<input type="text" value="1500"/>	LBS	RESISTIVE MOMENT	<input type="text" value="3.8"/>	K-FT	HOLDOWN CAPACITY	<input type="text" value="3105"/>	LBS

HOLD-DOWN SPECIFICATION

SIMPSON HTT4 HOLDOWN
FASTENED W/ 18-10D NAILS W/ 5/8" DIA. ALL-THREAD ROD



SHEARWALL DESIGN SUMMARY

SHEARWALL 107: 1ST - REAR EXT. WALL OF DINING ROOM

SHEARWALL PROPERTIES:

WALL HEIGHT, H	<input type="text" value="10.0"/>	FT.	MAX WALL OPENING HT, H _c	<input type="text" value="0.0"/>	FT.	SHEARWALL ASSEMBLY	<input type="text" value="P3"/>
WALL LENGTH, L	<input type="text" value="4.3"/>	FT.	QUALIFYING WALL LENGTH, L	<input type="text" value="4.3"/>	FT.		

CAPACITY EVALUATION:

TOTAL SHEAR LOAD ON WALL	<input type="text" value="1400"/>	LBS	<	ALLOWABLE SHEARWALL CAPACITY	<input type="text" value="2559"/>	LBS
--------------------------	-----------------------------------	-----	---	------------------------------	-----------------------------------	-----

SHEARWALL ASSEMBLY SPECIFICATION

P3 - 1-SIDE 7/16" OSB
FASTENED W/ 8D NAILS AT 3"D.C. PANEL EDGES & 12"D.C. PANEL FIELD - EDGES BLOCKED
ADEQUATE

OVERTURNING EVALUATION:

RESISTIVE DL	<input type="text" value="290"/>	PLF	OVERTURNING MOMENT	<input type="text" value="14.0"/>	K-FT	UPLIFT CONNECTOR DESIGN LOAD	<input type="text" value="2402"/>	LBS
DL AT ENDS OF WALL	<input type="text" value="870"/>	LBS	RESISTIVE MOMENT	<input type="text" value="3.8"/>	K-FT	HOLDOWN CAPACITY	<input type="text" value="3105"/>	LBS

HOLD-DOWN SPECIFICATION

SIMPSON HTT4 HOLDOWN
FASTENED W/ 18-10D NAILS W/ 5/8" DIA. ALL-THREAD ROD

SHEARWALL 108: 1ST - SIDE EXT. WALL OF KITCHEN

SHEARWALL PROPERTIES:

WALL HEIGHT, H	<input type="text" value="10.0"/>	FT.	MAX WALL OPENING HT, H _c	<input type="text" value="7.0"/>	FT.	SHEARWALL ASSEMBLY	<input type="text" value="P3"/>
WALL LENGTH, L	<input type="text" value="16.0"/>	FT.	QUALIFYING WALL LENGTH, L	<input type="text" value="11.0"/>	FT.		

CAPACITY EVALUATION:

TOTAL SHEAR LOAD ON WALL	<input type="text" value="1200"/>	LBS	<	ALLOWABLE SHEARWALL CAPACITY	<input type="text" value="3024"/>	LBS
--------------------------	-----------------------------------	-----	---	------------------------------	-----------------------------------	-----

SHEARWALL ASSEMBLY SPECIFICATION

P3 - 1-SIDE 7/16" OSB
FASTENED W/ 8D NAILS AT 3"D.C. PANEL EDGES & 12"D.C. PANEL FIELD - EDGES BLOCKED
ADEQUATE

OVERTURNING EVALUATION:

RESISTIVE DL	<input type="text" value="234"/>	PLF	OVERTURNING MOMENT	<input type="text" value="12.0"/>	K-FT	HOLD DOWN DESIGN LOAD	<input type="text" value="0"/>	LBS
DL AT ENDS OF WALL	<input type="text" value="400"/>	LBS	RESISTIVE MOMENT	<input type="text" value="21.8"/>	K-FT	HOLDOWN CAPACITY	<input type="text" value="0"/>	LBS

HOLD-DOWN SPECIFICATION

NO HOLDOWN REQUIRED



SHEARWALL DESIGN SUMMARY

SHEARWALL 109: 1ST - SIDE EXT. WALL OF GARAGE

SHEARWALL PROPERTIES:

WALL HEIGHT, H	<input type="text" value="11.0"/>	FT.	MAX WALL OPENING HT, H _c	<input type="text" value="7.0"/>	FT.	SHEARWALL ASSEMBLY	<input type="text" value="P1"/>
WALL LENGTH, L	<input type="text" value="27.3"/>	FT.	QUALIFYING WALL LENGTH, L	<input type="text" value="22.3"/>	FT.		

CAPACITY EVALUATION:

TOTAL SHEAR LOAD ON WALL	<input type="text" value="1000"/>	LBS	<	ALLOWABLE SHEARWALL CAPACITY	<input type="text" value="3329"/>	LBS
--------------------------	-----------------------------------	-----	---	------------------------------	-----------------------------------	-----

SHEARWALL ASSEMBLY SPECIFICATION

P1 - 1-SIDE 7/16" OSB
FASTENED W/ 8D NAILS AT 6"D.C. PANEL EDGES & 12"D.C. PANEL FIELD - EDGES BLOCKED
ADEQUATE

OVERTURNING EVALUATION:

RESISTIVE DL	<input type="text" value="275"/>	PLF	OVERTURNING MOMENT	<input type="text" value="11.0"/>	K-FT	UPLIFT CONNECTOR DESIGN LOAD	<input type="text" value="0"/>	LBS
DL AT ENDS OF WALL	<input type="text" value="400"/>	LBS	RESISTIVE MOMENT	<input type="text" value="67.8"/>	K-FT	HOLDOWN CAPACITY	<input type="text" value="0"/>	LBS

HOLD-DOWN SPECIFICATION

NO HOLDOWN REQUIRED

SHEARWALL 110: 1ST - FRONT EXT. WALL OF GARAGE

SHEARWALL PROPERTIES:

WALL HEIGHT, H	<input type="text" value="11.0"/>	FT.	MAX WALL OPENING HT, H _c	<input type="text" value="8.0"/>	FT.	SHEARWALL ASSEMBLY	<input type="text" value="P1"/>
WALL LENGTH, L	<input type="text" value="21.0"/>	FT.	QUALIFYING WALL LENGTH, L	<input type="text" value="18.0"/>	FT.		

CAPACITY EVALUATION:

TOTAL SHEAR LOAD ON WALL	<input type="text" value="1900"/>	LBS	<	ALLOWABLE SHEARWALL CAPACITY	<input type="text" value="1924"/>	LBS
--------------------------	-----------------------------------	-----	---	------------------------------	-----------------------------------	-----

SHEARWALL ASSEMBLY SPECIFICATION

P1 - 1-SIDE 7/16" OSB
FASTENED W/ 8D NAILS AT 6"D.C. PANEL EDGES & 12"D.C. PANEL FIELD - EDGES BLOCKED
ADEQUATE

OVERTURNING EVALUATION:

RESISTIVE DL	<input type="text" value="100"/>	PLF	OVERTURNING MOMENT	<input type="text" value="20.9"/>	K-FT	HOLD DOWN DESIGN LOAD	<input type="text" value="0"/>	LBS
DL AT ENDS OF WALL	<input type="text" value="800"/>	LBS	RESISTIVE MOMENT	<input type="text" value="23.3"/>	K-FT	HOLDOWN CAPACITY	<input type="text" value="0"/>	LBS

HOLD-DOWN SPECIFICATION

NO HOLDOWN REQUIRED



SHEARWALL DESIGN SUMMARY

SHEARWALL 111: 1ST - FRONT EXT. WALL OF GUEST ROOM

SHEARWALL PROPERTIES:

WALL HEIGHT, H	<input type="text" value="10.0"/>	FT.	MAX WALL OPENING HT, H _c	<input type="text" value="7.5"/>	FT.	SHEARWALL ASSEMBLY	<input type="text" value="P3"/>
WALL LENGTH, L	<input type="text" value="13.0"/>	FT.	QUALIFYING WALL LENGTH, L	<input type="text" value="7.0"/>	FT.		

CAPACITY EVALUATION:

TOTAL SHEAR LOAD ON WALL	<input type="text" value="1500"/>	LBS	<	ALLOWABLE SHEARWALL CAPACITY	<input type="text" value="2048"/>	LBS
--------------------------	-----------------------------------	-----	---	------------------------------	-----------------------------------	-----

SHEARWALL ASSEMBLY SPECIFICATION

P3 - 1-SIDE 7/16" OSB
FASTENED W/ 8D NAILS AT 3"D.C. PANEL EDGES & 12"D.C. PANEL FIELD - EDGES BLOCKED
ADEQUATE

OVERTURNING EVALUATION:

RESISTIVE DL	<input type="text" value="425"/>	PLF	OVERTURNING MOMENT	<input type="text" value="15.0"/>	K-FT	UPLIFT CONNECTOR DESIGN LOAD	<input type="text" value="0"/>	LBS
DL AT ENDS OF WALL	<input type="text" value="935"/>	LBS	RESISTIVE MOMENT	<input type="text" value="28.8"/>	K-FT	HOLDOWN CAPACITY	<input type="text" value="0"/>	LBS

HOLD-DOWN SPECIFICATION

NO HOLDOWN REQUIRED

SHEARWALL 112: 1ST - SIDE EXT. WALL OF GUEST RM BY ENTRY

SHEARWALL PROPERTIES:

WALL HEIGHT, H	<input type="text" value="10.0"/>	FT.	MAX WALL OPENING HT, H _c	<input type="text" value="0.0"/>	FT.	SHEARWALL ASSEMBLY	<input type="text" value="P1"/>
WALL LENGTH, L	<input type="text" value="13.2"/>	FT.	QUALIFYING WALL LENGTH, L	<input type="text" value="13.2"/>	FT.		

CAPACITY EVALUATION:

TOTAL SHEAR LOAD ON WALL	<input type="text" value="1500"/>	LBS	<	ALLOWABLE SHEARWALL CAPACITY	<input type="text" value="4422"/>	LBS
--------------------------	-----------------------------------	-----	---	------------------------------	-----------------------------------	-----

SHEARWALL ASSEMBLY SPECIFICATION

P1 - 1-SIDE 7/16" OSB
FASTENED W/ 8D NAILS AT 6"D.C. PANEL EDGES & 12"D.C. PANEL FIELD - EDGES BLOCKED
ADEQUATE

OVERTURNING EVALUATION:

RESISTIVE DL	<input type="text" value="234"/>	PLF	OVERTURNING MOMENT	<input type="text" value="15.0"/>	K-FT	HOLD DOWN DESIGN LOAD	<input type="text" value="0"/>	LBS
DL AT ENDS OF WALL	<input type="text" value="834"/>	LBS	RESISTIVE MOMENT	<input type="text" value="18.7"/>	K-FT	HOLDOWN CAPACITY	<input type="text" value="0"/>	LBS

HOLD-DOWN SPECIFICATION

NO HOLDOWN REQUIRED



SHEARWALL DESIGN SUMMARY

SHEARWALL 113: 1ST - REAR INT. WALL OF GARAGE

SHEARWALL PROPERTIES:

WALL HEIGHT, H	<input type="text" value="10.0"/>	FT.	MAX WALL OPENING HT, H _c	<input type="text" value="0.0"/>	FT.	SHEARWALL ASSEMBLY	<input type="text" value="P3"/>
WALL LENGTH, L	<input type="text" value="15.8"/>	FT.	QUALIFYING WALL LENGTH, L	<input type="text" value="15.8"/>	FT.		

CAPACITY EVALUATION:

TOTAL SHEAR LOAD ON WALL	<input type="text" value="3350"/>	LBS	<	ALLOWABLE SHEARWALL CAPACITY	<input type="text" value="9973"/>	LBS
--------------------------	-----------------------------------	-----	---	------------------------------	-----------------------------------	-----

SHEARWALL ASSEMBLY SPECIFICATION

P3 - 1-SIDE 7/16" OSB
FASTENED W/ 8D NAILS AT 3"D.C. PANEL EDGES & 12"D.C. PANEL FIELD - EDGES BLOCKED
ADEQUATE

OVERTURNING EVALUATION:

RESISTIVE DL	<input type="text" value="180"/>	PLF	OVERTURNING MOMENT	<input type="text" value="33.5"/>	K-FT	UPLIFT CONNECTOR DESIGN LOAD	<input type="text" value="1186"/>	LBS
DL AT ENDS OF WALL	<input type="text" value="125"/>	LBS	RESISTIVE MOMENT	<input type="text" value="14.7"/>	K-FT	HOLDOWN CAPACITY	<input type="text" value="3105"/>	LBS

HOLD-DOWN SPECIFICATION

SIMPSON HTT4 HOLDOWN
FASTENED W/ 18-10D NAILS W/ 5/8" DIA. ALL-THREAD ROD

SHEARWALL XXX: - NOT USED

SHEARWALL PROPERTIES:

WALL HEIGHT, H	<input type="text" value="0.0"/>	FT.	MAX WALL OPENING HT, H _c	<input type="text" value="0.0"/>	FT.	SHEARWALL ASSEMBLY	<input type="text" value="P1"/>
WALL LENGTH, L	<input type="text" value="0.0"/>	FT.	QUALIFYING WALL LENGTH, L	<input type="text" value="0.0"/>	FT.		

CAPACITY EVALUATION:

TOTAL SHEAR LOAD ON WALL	<input type="text" value="0"/>	LBS	#####	ALLOWABLE SHEARWALL CAPACITY	<input type="text" value="#DIV/0!"/>	LBS
--------------------------	--------------------------------	-----	-------	------------------------------	--------------------------------------	-----

SHEARWALL ASSEMBLY SPECIFICATION

P1 - 1-SIDE 7/16" OSB
FASTENED W/ 8D NAILS AT 6"D.C. PANEL EDGES & 12"D.C. PANEL FIELD - EDGES BLOCKED
#DIV/0!

OVERTURNING EVALUATION:

RESISTIVE DL	<input type="text" value="0"/>	PLF	OVERTURNING MOMENT	<input type="text" value="#DIV/0!"/>	K-FT	HOLD DOWN DESIGN LOAD	<input type="text" value="0"/>	LBS
DL AT ENDS OF WALL	<input type="text" value="0"/>	LBS	RESISTIVE MOMENT	<input type="text" value="0.0"/>	K-FT	HOLDOWN CAPACITY	<input type="text" value="0"/>	LBS

HOLD-DOWN SPECIFICATION

NO HOLDOWN REQUIRED



SHEARWALL DESIGN SUMMARY

SHEARWALL 1: BASEMENT - SIDE EXT. KNEEWALL OF REC RM WET BAR

SHEARWALL PROPERTIES:

WALL HEIGHT, H	<input type="text" value="2.8"/>	FT.	MAX WALL OPENING HT, H _c	<input type="text" value="0.0"/>	FT.	SHEARWALL ASSEMBLY	<input type="text" value="P3"/>
WALL LENGTH, L	<input type="text" value="6.8"/>	FT.	QUALIFYING WALL LENGTH, L	<input type="text" value="6.8"/>	FT.		

CAPACITY EVALUATION:

TOTAL SHEAR LOAD ON WALL	<input type="text" value="4250"/>	LBS	<	ALLOWABLE SHEARWALL CAPACITY	<input type="text" value="4253"/>	LBS
--------------------------	-----------------------------------	-----	---	------------------------------	-----------------------------------	-----

SHEARWALL ASSEMBLY SPECIFICATION

P3 - 1-SIDE 7/16" OSB
FASTENED W/ 8D NAILS AT 3"D.C. PANEL EDGES & 12"D.C. PANEL FIELD - EDGES BLOCKED
ADEQUATE

OVERTURNING EVALUATION:

RESISTIVE DL	<input type="text" value="334"/>	PLF	OVERTURNING MOMENT	<input type="text" value="11.7"/>	K-FT	UPLIFT CONNECTOR DESIGN LOAD	<input type="text" value="815"/>	LBS
DL AT ENDS OF WALL	<input type="text" value="400"/>	LBS	RESISTIVE MOMENT	<input type="text" value="6.2"/>	K-FT	HOLDOWN CAPACITY	<input type="text" value="3105"/>	LBS

HOLD-DOWN SPECIFICATION

SIMPSON HTT4 HOLDOWN
FASTENED W/ 18-10D NAILS W/ 5/8" DIA. ALL-THREAD ROD

SHEARWALL 2: BASEMENT - REAR EXT. WALL OF REC ROOM

SHEARWALL PROPERTIES:

WALL HEIGHT, H	<input type="text" value="8.0"/>	FT.	MAX WALL OPENING HT, H _c	<input type="text" value="1.5"/>	FT.	SHEARWALL ASSEMBLY	<input type="text" value="P1"/>
WALL LENGTH, L	<input type="text" value="17.0"/>	FT.	QUALIFYING WALL LENGTH, L	<input type="text" value="12.0"/>	FT.		

CAPACITY EVALUATION:

TOTAL SHEAR LOAD ON WALL	<input type="text" value="2850"/>	LBS	<	ALLOWABLE SHEARWALL CAPACITY	<input type="text" value="4032"/>	LBS
--------------------------	-----------------------------------	-----	---	------------------------------	-----------------------------------	-----

SHEARWALL ASSEMBLY SPECIFICATION

P1 - 1-SIDE 7/16" OSB
FASTENED W/ 8D NAILS AT 6"D.C. PANEL EDGES & 12"D.C. PANEL FIELD - EDGES BLOCKED
ADEQUATE

OVERTURNING EVALUATION:

RESISTIVE DL	<input type="text" value="520"/>	PLF	OVERTURNING MOMENT	<input type="text" value="22.8"/>	K-FT	HOLD DOWN DESIGN LOAD	<input type="text" value="0"/>	LBS
DL AT ENDS OF WALL	<input type="text" value="800"/>	LBS	RESISTIVE MOMENT	<input type="text" value="53.2"/>	K-FT	HOLDOWN CAPACITY	<input type="text" value="0"/>	LBS

HOLD-DOWN SPECIFICATION

NO HOLDOWN REQUIRED



SHEARWALL DESIGN SUMMARY

SHEARWALL 3: BASEMENT - SIDE EXT. WALL OF REC ROOM

SHEARWALL PROPERTIES:

WALL HEIGHT, H	<input type="text" value="8.0"/>	FT.	MAX WALL OPENING HT, H _c	<input type="text" value="6.7"/>	FT.	SHEARWALL ASSEMBLY	<input type="text" value="P3"/>
WALL LENGTH, L	<input type="text" value="10.8"/>	FT.	QUALIFYING WALL LENGTH, L	<input type="text" value="4.8"/>	FT.		

CAPACITY EVALUATION:

TOTAL SHEAR LOAD ON WALL	<input type="text" value="1125"/>	LBS	<	ALLOWABLE SHEARWALL CAPACITY	<input type="text" value="1126"/>	LBS
--------------------------	-----------------------------------	-----	---	------------------------------	-----------------------------------	-----

SHEARWALL ASSEMBLY SPECIFICATION

P3 - 1-SIDE 7/16" OSB
FASTENED W/ 8D NAILS AT 3"D.C. PANEL EDGES & 12"D.C. PANEL FIELD - EDGES BLOCKED
ADEQUATE

OVERTURNING EVALUATION:

RESISTIVE DL	<input type="text" value="334"/>	PLF	OVERTURNING MOMENT	<input type="text" value="9.0"/>	K-FT	UPLIFT CONNECTOR DESIGN LOAD	<input type="text" value="0"/>	LBS
DL AT ENDS OF WALL	<input type="text" value="2000"/>	LBS	RESISTIVE MOMENT	<input type="text" value="24.5"/>	K-FT	HOLDOWN CAPACITY	<input type="text" value="0"/>	LBS

HOLD-DOWN SPECIFICATION

NO HOLDOWN REQUIRED

SHEARWALL 4: BASEMENT - REAR EXT. WALL OF CRAWLSPACE

SHEARWALL PROPERTIES:

WALL HEIGHT, H	<input type="text" value="8.0"/>	FT.	MAX WALL OPENING HT, H _c	<input type="text" value="0.0"/>	FT.	SHEARWALL ASSEMBLY	<input type="text" value="P1"/>
WALL LENGTH, L	<input type="text" value="15.0"/>	FT.	QUALIFYING WALL LENGTH, L	<input type="text" value="15.0"/>	FT.		

CAPACITY EVALUATION:

TOTAL SHEAR LOAD ON WALL	<input type="text" value="4000"/>	LBS	<	ALLOWABLE SHEARWALL CAPACITY	<input type="text" value="5040"/>	LBS
--------------------------	-----------------------------------	-----	---	------------------------------	-----------------------------------	-----

SHEARWALL ASSEMBLY SPECIFICATION

P1 - 1-SIDE 7/16" OSB
FASTENED W/ 8D NAILS AT 6"D.C. PANEL EDGES & 12"D.C. PANEL FIELD - EDGES BLOCKED
ADEQUATE

OVERTURNING EVALUATION:

RESISTIVE DL	<input type="text" value="505"/>	PLF	OVERTURNING MOMENT	<input type="text" value="32.0"/>	K-FT	HOLD DOWN DESIGN LOAD	<input type="text" value="0"/>	LBS
DL AT ENDS OF WALL	<input type="text" value="1000"/>	LBS	RESISTIVE MOMENT	<input type="text" value="43.1"/>	K-FT	HOLDOWN CAPACITY	<input type="text" value="0"/>	LBS

HOLD-DOWN SPECIFICATION

NO HOLDOWN REQUIRED



SHEARWALL DESIGN SUMMARY

SHEARWALL 5: BASEMENT - SIDE EXT. WALL OF CRAWLSPACE

SHEARWALL PROPERTIES:

WALL HEIGHT, H	<input type="text" value="5.3"/>	FT.	MAX WALL OPENING HT, H _c	<input type="text" value="0.0"/>	FT.	SHEARWALL ASSEMBLY	<input type="text" value="P1"/>
WALL LENGTH, L	<input type="text" value="25.5"/>	FT.	QUALIFYING WALL LENGTH, L	<input type="text" value="25.5"/>	FT.		

CAPACITY EVALUATION:

TOTAL SHEAR LOAD ON WALL	<input type="text" value="2850"/>	LBS	<	ALLOWABLE SHEARWALL CAPACITY	<input type="text" value="8568"/>	LBS
--------------------------	-----------------------------------	-----	---	------------------------------	-----------------------------------	-----

SHEARWALL ASSEMBLY SPECIFICATION

P1 - 1-SIDE 7/16" OSB
FASTENED W/ 8D NAILS AT 6"O.C. PANEL EDGES & 12"O.C. PANEL FIELD - EDGES BLOCKED
ADEQUATE

OVERTURNING EVALUATION:

RESISTIVE DL	<input type="text" value="334"/>	PLF	OVERTURNING MOMENT	<input type="text" value="15.0"/>	K-FT	UPLIFT CONNECTOR DESIGN LOAD	<input type="text" value="0"/>	LBS
DL AT ENDS OF WALL	<input type="text" value="800"/>	LBS	RESISTIVE MOMENT	<input type="text" value="77.4"/>	K-FT	HOLDOWN CAPACITY	<input type="text" value="0"/>	LBS

HOLD-DOWN SPECIFICATION

NO HOLDOWN REQUIRED

SHEARWALL 6: BASEMENT - KNEEWALL AT CRAWLSPACE BY REC RM

SHEARWALL PROPERTIES:

WALL HEIGHT, H	<input type="text" value="5.3"/>	FT.	MAX WALL OPENING HT, H _c	<input type="text" value="0.0"/>	FT.	SHEARWALL ASSEMBLY	<input type="text" value="P0"/>
WALL LENGTH, L	<input type="text" value="12.0"/>	FT.	QUALIFYING WALL LENGTH, L	<input type="text" value="12.0"/>	FT.		

CAPACITY EVALUATION:

TOTAL SHEAR LOAD ON WALL	<input type="text" value="1025"/>	LBS	<	ALLOWABLE SHEARWALL CAPACITY	<input type="text" value="2412"/>	LBS
--------------------------	-----------------------------------	-----	---	------------------------------	-----------------------------------	-----

SHEARWALL ASSEMBLY SPECIFICATION

P0 - 1-SIDE 7/16" OSB
FASTENED W/ 8D NAILS AT 6"O.C. PANEL EDGES & 12"O.C. PANEL FIELD - UNBLOCKED
ADEQUATE

OVERTURNING EVALUATION:

RESISTIVE DL	<input type="text" value="100"/>	PLF	OVERTURNING MOMENT	<input type="text" value="5.4"/>	K-FT	HOLD DOWN DESIGN LOAD	<input type="text" value="0"/>	LBS
DL AT ENDS OF WALL	<input type="text" value="150"/>	LBS	RESISTIVE MOMENT	<input type="text" value="5.4"/>	K-FT	HOLDOWN CAPACITY	<input type="text" value="0"/>	LBS

HOLD-DOWN SPECIFICATION

NO HOLDOWN REQUIRED



SHEARWALL DESIGN SUMMARY

SHEARWALL 7: BASEMENT - KNEEWALL AT CRAWLSPACE BY STARIS

SHEARWALL PROPERTIES:

WALL HEIGHT, H FT. MAX WALL OPENING HT, H_c FT.
WALL LENGTH, L FT. QUALIFYING WALL LENGTH, L FT. SHEARWALL ASSEMBLY

CAPACITY EVALUATION:

TOTAL SHEAR LOAD ON WALL LBS < ALLOWABLE SHEARWALL CAPACITY LBS

SHEARWALL ASSEMBLY SPECIFICATION

PO - 1-SIDE 7/16" OSB
FASTENED W/ 8D NAILS AT 6"O.C. PANEL EDGES & 12"O.C. PANEL FIELD - UNBLOCKED
ADEQUATE

OVERTURNING EVALUATION:

RESISTIVE DL PLF OVERTURNING MOMENT K-FT UPLIFT CONNECTOR DESIGN LOAD LBS
DL AT ENDS OF WALL LBS RESISTIVE MOMENT K-FT HOLDOWN CAPACITY LBS

HOLD-DOWN SPECIFICATION

NO HOLDOWN REQUIRED

SHEARWALL XXX: - NOT USED

SHEARWALL PROPERTIES:

WALL HEIGHT, H FT. MAX WALL OPENING HT, H_c FT.
WALL LENGTH, L FT. QUALIFYING WALL LENGTH, L FT. SHEARWALL ASSEMBLY

CAPACITY EVALUATION:

TOTAL SHEAR LOAD ON WALL LBS ##### ALLOWABLE SHEARWALL CAPACITY LBS

SHEARWALL ASSEMBLY SPECIFICATION

PO - 1-SIDE 7/16" OSB
FASTENED W/ 8D NAILS AT 6"O.C. PANEL EDGES & 12"O.C. PANEL FIELD - UNBLOCKED
#DIV/0!

OVERTURNING EVALUATION:

RESISTIVE DL PLF OVERTURNING MOMENT K-FT HOLD DOWN DESIGN LOAD LBS
DL AT ENDS OF WALL LBS RESISTIVE MOMENT K-FT HOLDOWN CAPACITY LBS

HOLD-DOWN SPECIFICATION

NO HOLDOWN REQUIRED

J DESIGNS
3440 97TH AVE

MERCER ISLAND, WA

SHEAR WALL CALCULATIONS - SEISMIC

REVIEWED BY:

JANUARY 21, 2019

PARAMETERS:

SINGLE FAMILY HOME

DESIGN WIND SPEED: 110 MPH

WIND EXPOSURE CATEGORY: C

SEISMIC DESIGN CATEGORY: D

CODE & DESIGN STANDARD: 2015 IBC CH. 1609, ASCE 7-10 CH. 26-30



SEISMIC CALCULATION - ASCE 7-10

SEISMIC DESIGN CATEGORY:

USER INPUTS:

SITE CLASS	D
SPECTRAL RESPONSE ACCELERATION 0.2 SEC, S_s	1.384
SPECTRAL RESPONSE ACCELERATION 1.0 SEC, S₁	0.532
OCCUPANCY CATEGORY	II

VARIABLES:

SITE COEFFICIENT, F _A	1.00
SITE COEFFICIENT, F _V	1.50

CALCULATED VALUES:

MAXIMUM SPECTRAL RESPONSE ACCELERATION, S_{MS}	1.384
MAXIMUM SPECTRAL RESPONSE ACCELERATION, S_{M1}	0.798
DESIGN SPECTRAL RESPONSE ACCELERATION, S_{DS}	0.923
DESIGN SPECTRAL RESPONSE ACCELERATION, S_{D1}	0.532
SEISMIC DESIGN CATEGORY (SHORT TERM)	D
SEISMIC DESIGN CATEGORY (1.0 SECOND TERM)	D

BUILDING PERIOD DETERMINATION:

USER INPUTS:

BUILDING PERIOD COEFFICIENT, C _T	0.020
LONG-PERIOD TRANS PERIOD, T _L (SEC)	6
HT. ABV BASE TO HIGHEST LEVEL, h _N	26

CALCULATED VALUES:

APPROXIMATE FUNDAMENTAL PERIOD, T _A , T	0.230
T ₀	0.115
T _B	0.577
SPECTRAL RESPONSE ACCELERATION, S _A (G)	0.923

EQUIVALENT LATERAL FORCE PROCEDURE

DEAD LOAD CALCULATION:

LEVEL	STORY HT. (FT.)	AREA (FT ²)	DEAD LOAD (PSF)	DL OF EXT WALL TRIBUTARY TO LEVEL (KIPS)	TOTAL LEVEL DL
1	8.0	932	10	28.9	38 K
2	10.0	2046	10	19.6	40 K
3	8.0	1566	17	7.6	34 K
4	0.0	0	0	0.0	0 K
5	0.0	0	0	0.0	0 K
6	0.0	0	0	0.0	0 K
7	0.0	0	0	0.0	0 K
8	0.0	0	0	0.0	0 K
9	0.0	0	0	0.0	0 K
10	0.0	0	0	0.0	0 K

TOTAL DEAD LOAD OF STRUCTURE 113 KIPS

SEISMIC RESPONSE COEFFICIENT:

	TRANSVERSE	LONGITUDINAL
RESPONSE MODIFICATION FACTOR, R	6.5	6.5
OCCUPANCY IMPORTANCE FACTOR, I _e	1.00	1.00
SEISMIC RESPONSE COEFFICIENT, C _s	0.142	0.142

BASE SHEARS:

ULTIMATE LOADS		x 0.7 =	ALLOWABLE LOADS	
TRANSVERSE	LONGITUDINAL		TRANSVERSE	LONGITUDINAL
16 K	16 K		11 K	11 K

STORY SHEAR CALCULATION:

DISTRIBUTION EXPONENT	1.00					
	ULTIMATE LOADS		x 0.7 =		ALLOWABLE LOADS	
	TRANSVERSE	LONGITUDINAL	TRANSVERSE	LONGITUDINAL	TRANSVERSE	LONGITUDINAL
LEVEL	VERT. DIST. FACTOR, C _{dh}	STORY SHEAR, F _x	STORY SHEAR, F _x	Σ STORY SHEAR	STORY SHEAR, F _x	Σ STORY SHEAR
1	0.159	2.5 K	2.5 K	1.8 K	11.2 K	11.2 K
2	0.376	6.0 K	6.0 K	4.2 K	9.4 K	9.4 K
3	0.465	7.4 K	7.4 K	5.2 K	5.2 K	5.2 K
4	0.000	0.0 K	0.0 K	0.0 K	0.0 K	0.0 K
5	0.00	0.0 K	0.0 K	0.0 K	0.0 K	0.0 K
6	0.00	0.0 K	0.0 K	0.0 K	0.0 K	0.0 K
7	0.00	0.0 K	0.0 K	0.0 K	0.0 K	0.0 K
8	0.00	0.0 K	0.0 K	0.0 K	0.0 K	0.0 K
9	0.00	0.0 K	0.0 K	0.0 K	0.0 K	0.0 K
10	0.00	0.0 K	0.0 K	0.0 K	0.0 K	0.0 K



TRIS. LOAD CALCS:

- ALL RESULTANT LOCATIONS WERE DETERMINED BASED ON DISTANCE + MAGNITUDE OF LOAD FOR EA. SHEARWALL
- SOME RESULTANT FORCES ARE LESS THAN THE REQUIRED SUPPORT REACTIONS BASED ON A FLEXIBLE DIAPHRAGM. IT IS OUR PROFESSIONAL OPINION THAT THE MAGNITUDE OF THE PROVIDED LOADS ARE WITHIN AN ACCEPTABLE RANGE OF THESE REQ'D LOADS + THE TOTAL LOAD IS RESISTED BY THE SHEARWALLS SHOWN.

DIAPHRAGM CAPACITIES:

- UNSLOTTED DIAPHRAGM w 8d COMMON NAILS @ 6" o.c. EDGE NAILING + 2" MIN. NOMINAL FRAMING w/ 1/16" MIN. SHEATHING THICKNESS.

- MAX CAPACITY (CASE #1):

$$\frac{645 \text{ PLF} (0.92)}{2} = 297 \text{ PLF} \quad \frac{460 \text{ PLF} (0.92)}{2} = 212 \text{ PLF}$$

- MAX CAPACITY (CASE #2):

$$\frac{475 \text{ PLF} (0.92)}{2} = 218 \text{ PLF} \quad \frac{340 \text{ PLF} (0.92)}{2} = 156 \text{ PLF}$$

▲ = LOAD REQ'D PER FLEXIBLE DIAPHRAGM
■ = PROVIDED

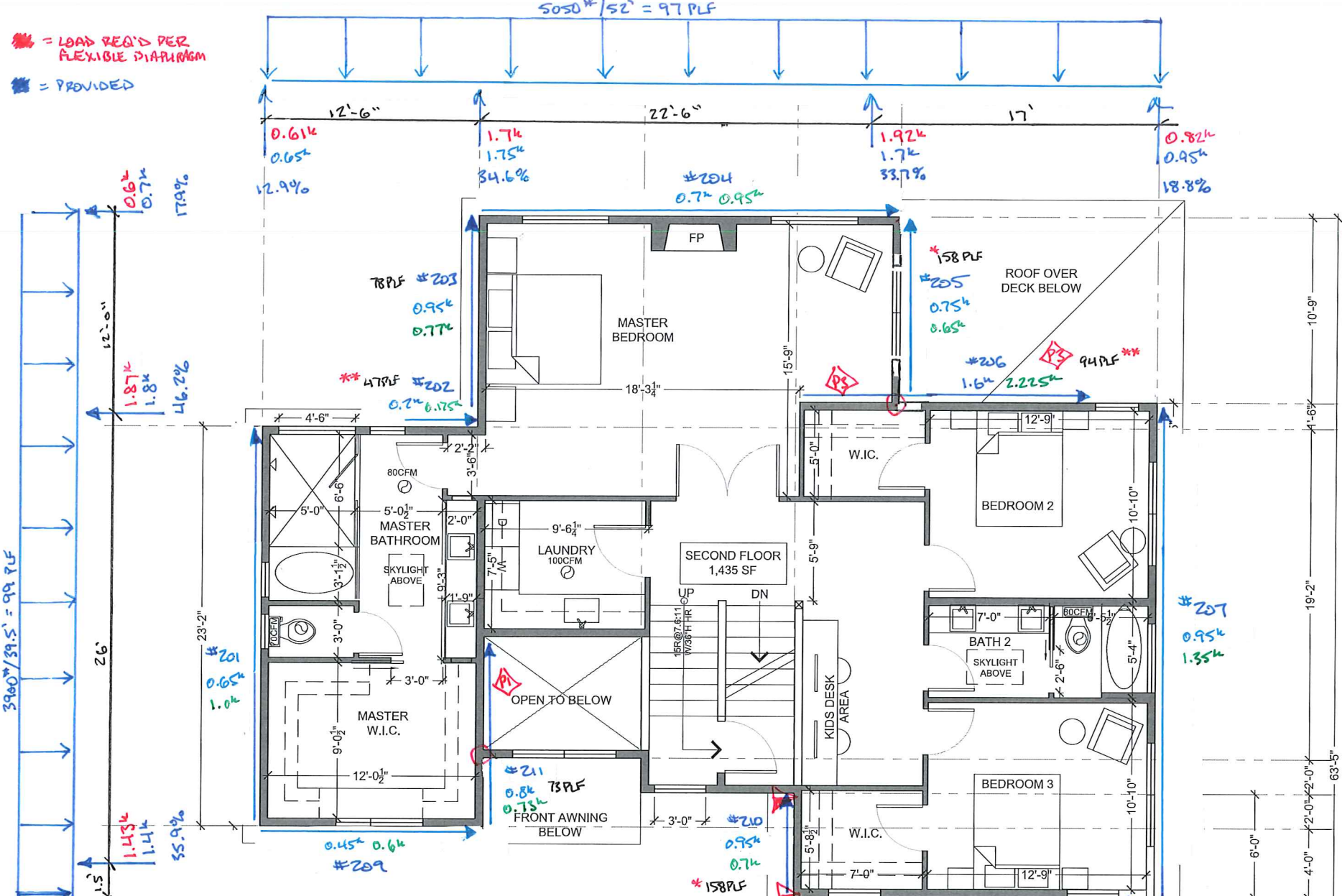

WIND DESIGN: EX. C NORMAL $K_{zt}=1.0$

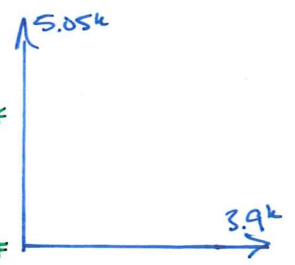

SEISMIC DESIGN:

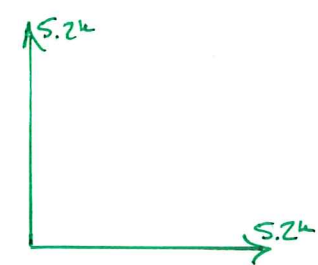

* SW #203 (78 PLF) + SW #211 (75 PLF) AS WELL AS SW #205 (158 PLF) + SW #210 (158 PLF) ARE WITHIN AN ACCEPTABLE TOLERANCE TO BE CONSIDERED PROPORTIONAL ALONG THEIR RESPECTIVE WALL LINES *

* SW #202 + SW #206 UNIT SHEARS COMPARED BASED ON SHEAR WALL CAPACITY:
 $\frac{P_1}{P_3} = \frac{336}{650} = 0.533$
 $94 (0.533) = 50 \text{ PLF}$
 47 PLF + 50 PLF ARE WITHIN AN ACCEPTABLE TOLERANCE TO BE CONSIDERED PROPORTIONAL. *

1 UPPER FLOOR PLAN

SCALE: 1/4" = 1'-0"

SUBMITTAL	
SD	9
DD	11

3440 97TH AVE
 MERCER ISLAND, WA

DRAWING INFORMATION
 OWNER:
 MY BACKYARD, LLC

PROJECT#

DRAWING NAME:
ROOF PLAN

A2.1



WIND DESIGN: EXP. C 110MPH

SEISMIC DESIGN:

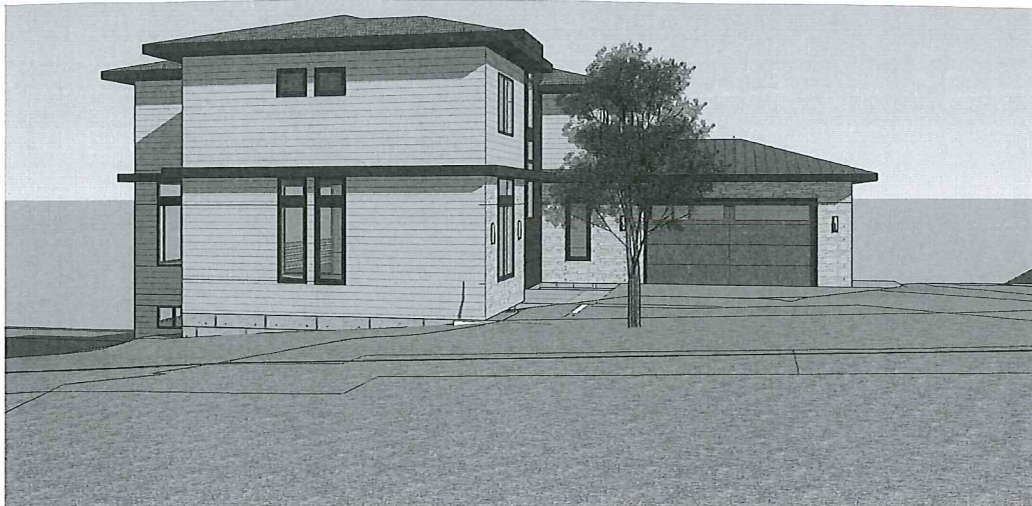
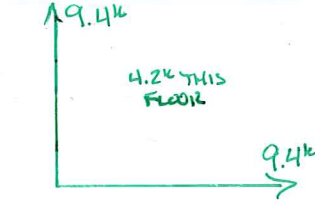
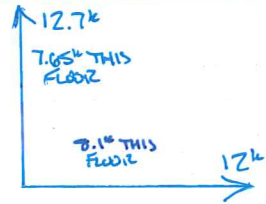

▲▲▲ = LOAD REQUIRED PER FLEXIBLE DIAPHRAGM
▲▲ = PROVIDED

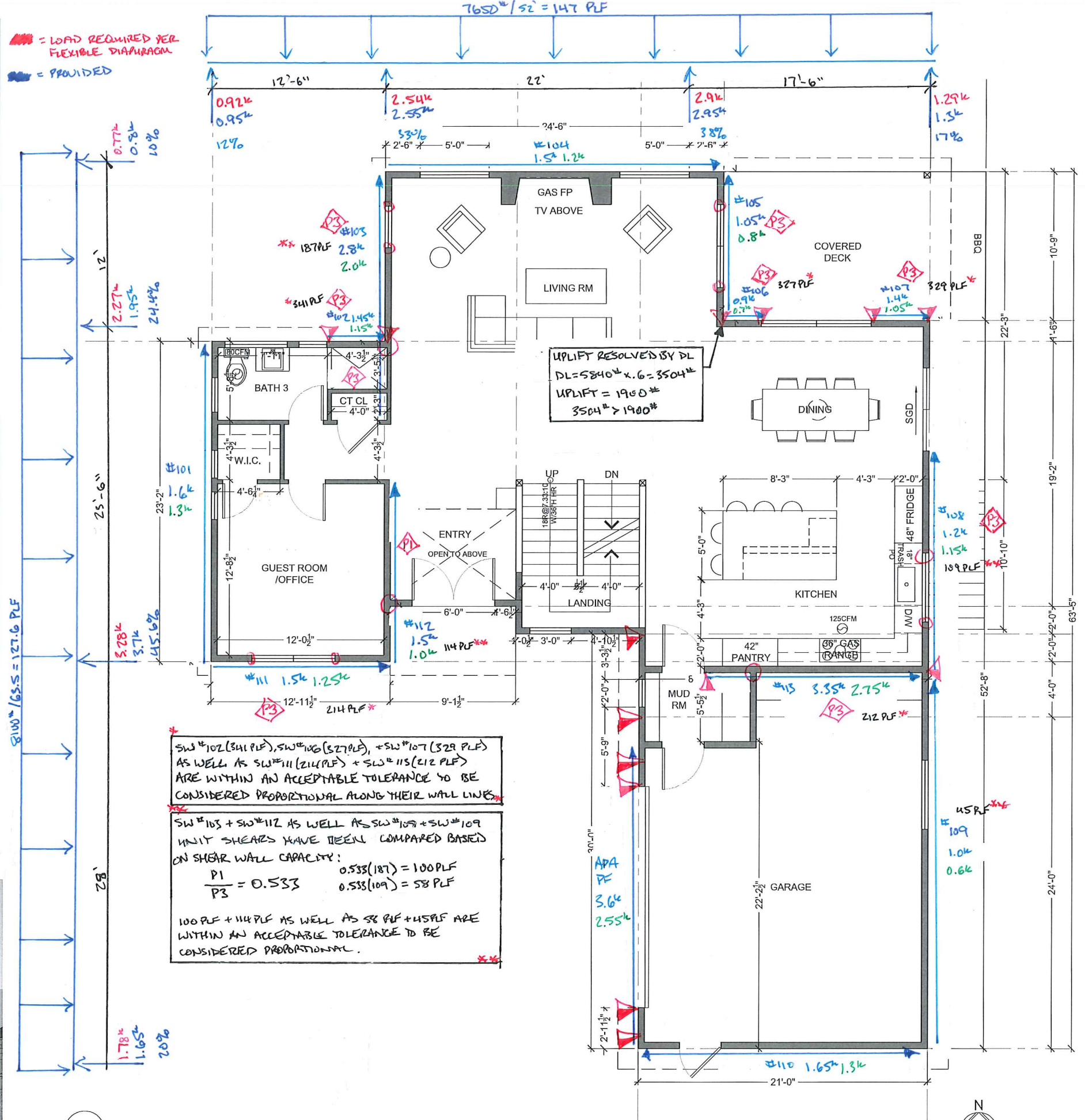

1 MAIN FLOOR PLAN

SCALE: 1/4" = 1'-0"



2425 SW ROXBUR
 SEATTLE, WA 981
 206.234.4411
 JACQUELINE
 JDESIGNSSEATTLE

SUBMITTAL	1
SD	9
DD	11

3440 97TH AVE
 MERCER ISLAND, WA

DRAWING INFORMATION
 OWNER:
 MY BACKYARD, LLC

PROJECT#

DRAWING NAME:
 FLOOR PL

A2.

SUBMITTAL	
SD	9
DD	11

3440 97TH AVE
MERCER ISLAND, WA

DRAWING INFORMA

OWNER:
MY BACKYARD, LLC

PROJECT#

DRAWING NAME:
FLOOR PL

A2.1

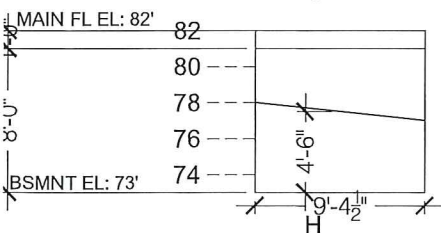
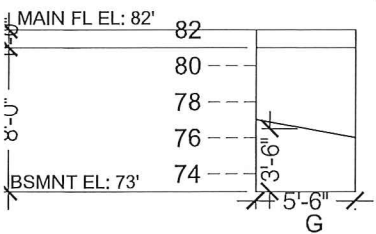
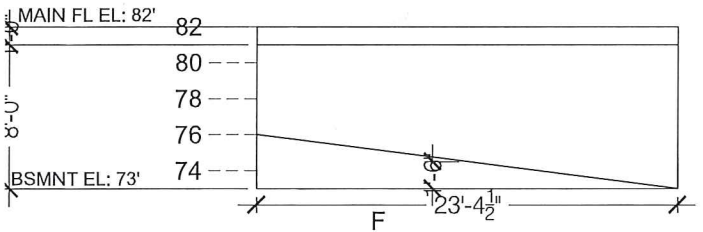
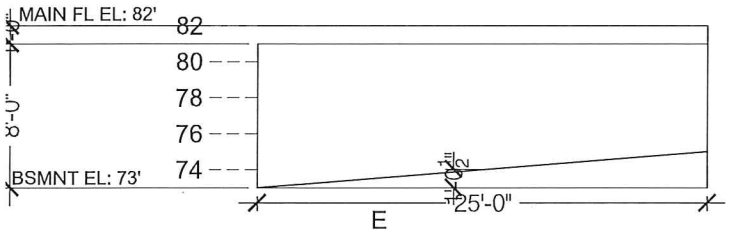
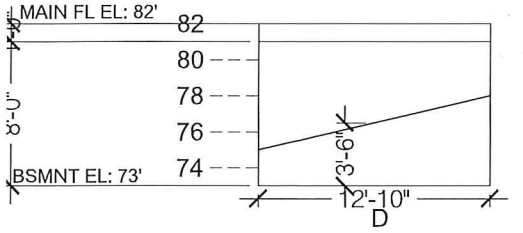
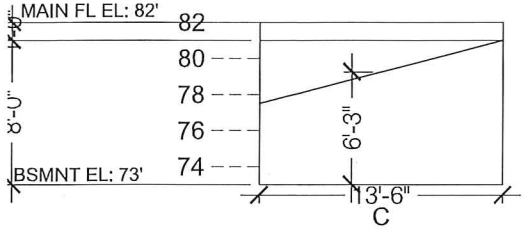
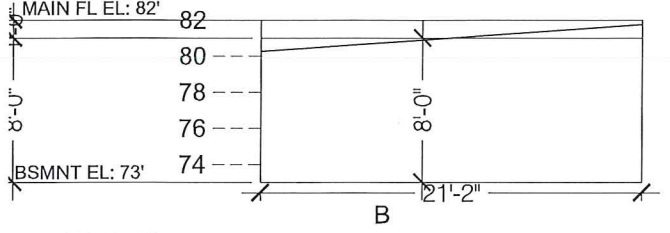
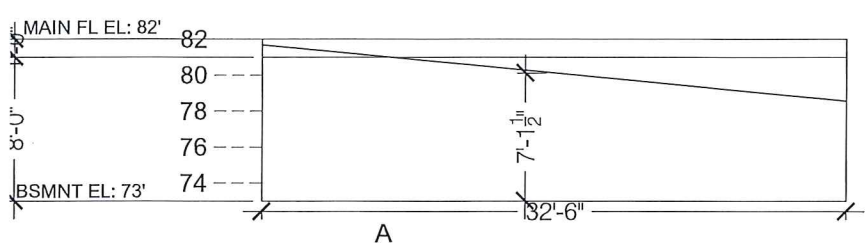

BASEMENT COVERAGE CALCS:

- A 32.5' 89% = 29'
- B 21' X 100% = 21'
- C 13.5' X 78% = 10.5'
- D 12.8 X 44% = 5.5'
- E 25' X 13% = 3'
- F 23' X 19% = 4.4'
- G 5.5 X 44% = 2.4'
- H 9.5 X 56% = 5.3'
- TOTALS 142.8', N/A, 81.1'

901 SF * 81.1' / 142.8' = 511.7 SF
EXCLUDED BASEMENT FLOOR AREA

LOAD REQUIRED PER FLEXIBLE DIAGRAM
PROVIDED

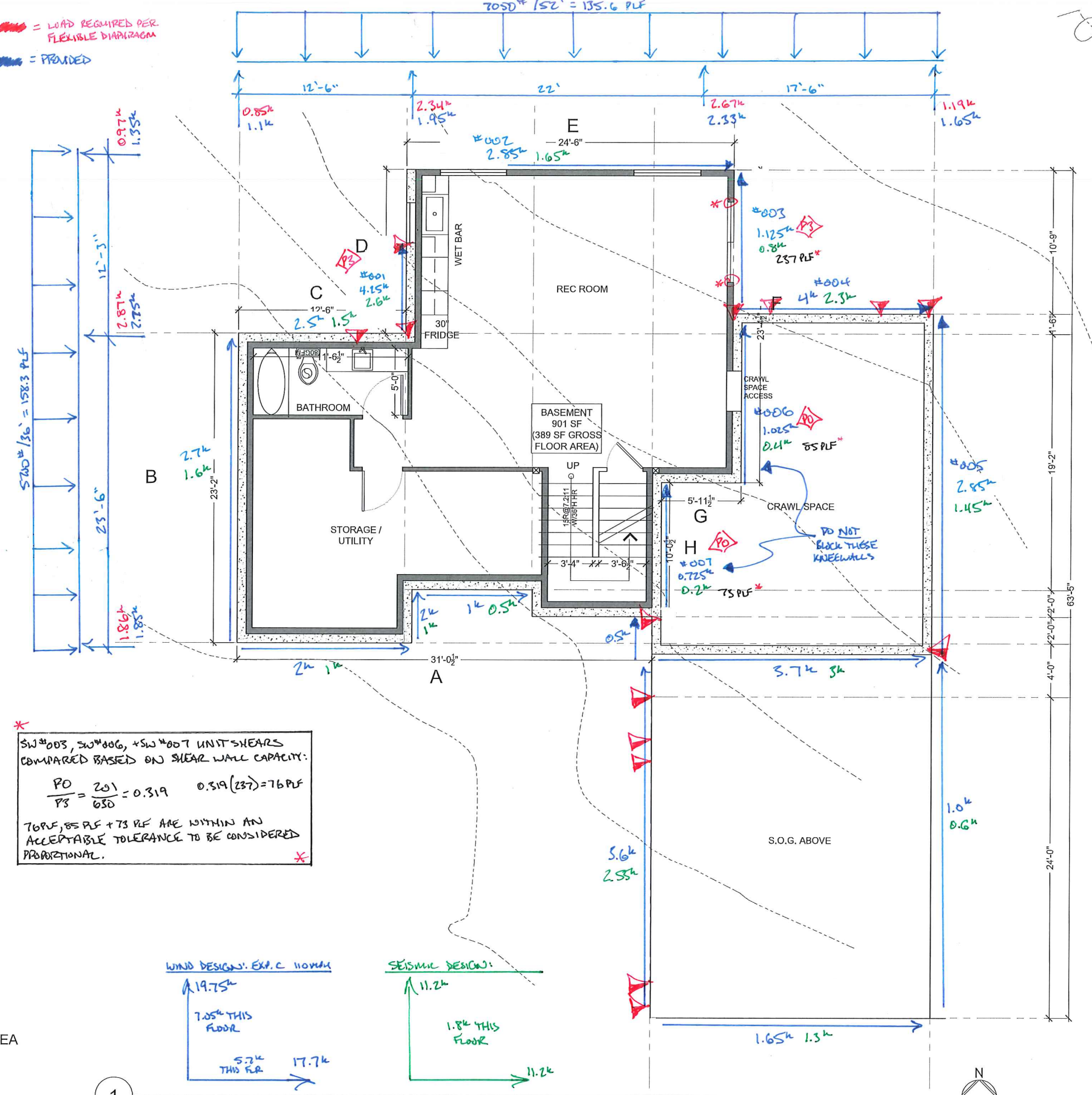

* SW#005, SW#006, +SW#007 UNIT SHEARS COMPARED BASED ON SHEAR WALL CAPACITY:
 $\frac{PO}{PS} = \frac{201}{630} = 0.319$ $0.319(237) = 76 \text{ PLF}$
TOPF, 85 PLF + 73 PLF ARE WITHIN AN ACCEPTABLE TOLERANCE TO BE CONSIDERED PROPORTIONAL.*

WIND DESIGN: EXP. C 110MMH
↑ 19.75k
7.05k THIS FLOOR
5.7k THIS FLR
17.7k

SEISMIC DESIGN:
↑ 11.2k
1.8k THIS FLOOR
11.2k

BSMNT WALL COVERAGE DIAGRAMS

1 BASEMENT PLAN

SCALE: 1/4" = 1'-0"

SHEARWALL DESIGN SUMMARY

SHEARWALL 201: 2ND - SIDE EXT. WALL OF MASTER WIC/MAST BD

SHEARWALL PROPERTIES:

WALL HEIGHT, H	<input type="text" value="8.0"/>	FT.	MAX WALL OPENING HT, H _c	<input type="text" value="1.5"/>	FT.	SHEARWALL ASSEMBLY	<input type="text" value="P1"/>
WALL LENGTH, L	<input type="text" value="23.2"/>	FT.	QUALIFYING WALL LENGTH, L	<input type="text" value="18.2"/>	FT.		

CAPACITY EVALUATION:

TOTAL SHEAR LOAD ON WALL	<input type="text" value="1000"/>	LBS	<	ALLOWABLE SHEARWALL CAPACITY	<input type="text" value="4340"/>	LBS
--------------------------	-----------------------------------	-----	---	------------------------------	-----------------------------------	-----

SHEARWALL ASSEMBLY SPECIFICATION

P1 - 1-SIDE 7/16" OSB
 FASTENED W/ 8D NAILS AT 6"D.C. PANEL EDGES & 12"D.C. PANEL FIELD - EDGES BLOCKED
ADEQUATE

OVERTURNING EVALUATION:

RESISTIVE DL	<input type="text" value="134"/>	PLF	OVERTURNING MOMENT	<input type="text" value="8.0"/>	K-FT	HOLD DOWN DESIGN LOAD	<input type="text" value="0"/>	LBS
DL AT ENDS OF WALL	<input type="text" value="100"/>	LBS	RESISTIVE MOMENT	<input type="text" value="18.0"/>	K-FT	HOLD DOWN CAPACITY	<input type="text" value="0"/>	LBS

HOLD-DOWN SPECIFICATION

NO HOLD DOWN REQUIRED

SHEARWALL 202: 2ND - REAR EXT. WALL OF MASTER BATH

SHEARWALL PROPERTIES:

WALL HEIGHT, H	<input type="text" value="8.0"/>	FT.	MAX WALL OPENING HT, H _c	<input type="text" value="0.0"/>	FT.	SHEARWALL ASSEMBLY	<input type="text" value="P1"/>
WALL LENGTH, L	<input type="text" value="4.3"/>	FT.	QUALIFYING WALL LENGTH, L	<input type="text" value="4.3"/>	FT.		

CAPACITY EVALUATION:

TOTAL SHEAR LOAD ON WALL	<input type="text" value="175"/>	LBS	<	ALLOWABLE SHEARWALL CAPACITY	<input type="text" value="1016"/>	LBS
--------------------------	----------------------------------	-----	---	------------------------------	-----------------------------------	-----

SHEARWALL ASSEMBLY SPECIFICATION

P1 - 1-SIDE 7/16" OSB
 FASTENED W/ 8D NAILS AT 6"D.C. PANEL EDGES & 12"D.C. PANEL FIELD - EDGES BLOCKED
ADEQUATE

OVERTURNING EVALUATION:

RESISTIVE DL	<input type="text" value="260"/>	PLF	OVERTURNING MOMENT	<input type="text" value="1.4"/>	K-FT	HOLD DOWN DESIGN LOAD	<input type="text" value="0"/>	LBS
DL AT ENDS OF WALL	<input type="text" value="195"/>	LBS	RESISTIVE MOMENT	<input type="text" value="1.5"/>	K-FT	HOLD DOWN CAPACITY	<input type="text" value="0"/>	LBS

HOLD-DOWN SPECIFICATION

NO HOLD DOWN REQUIRED



SHEARWALL DESIGN SUMMARY

SHEARWALL 203: 2ND - SIDE EXT. WALL OF MASTER BD BY BATH

SHEARWALL PROPERTIES:

WALL HEIGHT, H	<input type="text" value="8.0"/>	FT.	MAX WALL OPENING HT, H _c	<input type="text" value="0.0"/>	FT.	SHEARWALL ASSEMBLY	<input type="text" value="P1"/>
WALL LENGTH, L	<input type="text" value="12.3"/>	FT.	QUALIFYING WALL LENGTH, L	<input type="text" value="12.3"/>	FT.		

CAPACITY EVALUATION:

TOTAL SHEAR LOAD ON WALL	<input type="text" value="770"/>	LBS	<	ALLOWABLE SHEARWALL CAPACITY	<input type="text" value="2928"/>	LBS
--------------------------	----------------------------------	-----	---	------------------------------	-----------------------------------	-----

SHEARWALL ASSEMBLY SPECIFICATION

P1 - 1-SIDE 7/16" OSB
FASTENED W/ BD NAILS AT 6"D.C. PANEL EDGES & 12"D.C. PANEL FIELD - EDGES BLOCKED
ADEQUATE

OVERTURNING EVALUATION:

RESISTIVE DL	<input type="text" value="134"/>	PLF	OVERTURNING MOMENT	<input type="text" value="6.2"/>	K-FT	UPLIFT CONNECTOR DESIGN LOAD	<input type="text" value="0"/>	LBS
DL AT ENDS OF WALL	<input type="text" value="250"/>	LBS	RESISTIVE MOMENT	<input type="text" value="6.2"/>	K-FT	HOLDOWN CAPACITY	<input type="text" value="0"/>	LBS

HOLD-DOWN SPECIFICATION

NO HOLDOWN REQUIRED

SHEARWALL 204: 2ND - REAR EXT. WALL OF MASTER BD

SHEARWALL PROPERTIES:

WALL HEIGHT, H	<input type="text" value="8.0"/>	FT.	MAX WALL OPENING HT, H _c	<input type="text" value="4.0"/>	FT.	SHEARWALL ASSEMBLY	<input type="text" value="P1"/>
WALL LENGTH, L	<input type="text" value="24.5"/>	FT.	QUALIFYING WALL LENGTH, L	<input type="text" value="14.5"/>	FT.		

CAPACITY EVALUATION:

TOTAL SHEAR LOAD ON WALL	<input type="text" value="950"/>	LBS	<	ALLOWABLE SHEARWALL CAPACITY	<input type="text" value="2928"/>	LBS
--------------------------	----------------------------------	-----	---	------------------------------	-----------------------------------	-----

SHEARWALL ASSEMBLY SPECIFICATION

P1 - 1-SIDE 7/16" OSB
FASTENED W/ BD NAILS AT 6"D.C. PANEL EDGES & 12"D.C. PANEL FIELD - EDGES BLOCKED
ADEQUATE

OVERTURNING EVALUATION:

RESISTIVE DL	<input type="text" value="215"/>	PLF	OVERTURNING MOMENT	<input type="text" value="7.6"/>	K-FT	HOLD DOWN DESIGN LOAD	<input type="text" value="0"/>	LBS
DL AT ENDS OF WALL	<input type="text" value="200"/>	LBS	RESISTIVE MOMENT	<input type="text" value="32.7"/>	K-FT	HOLDOWN CAPACITY	<input type="text" value="0"/>	LBS

HOLD-DOWN SPECIFICATION

NO HOLDOWN REQUIRED



SHEARWALL DESIGN SUMMARY

SHEARWALL 205: 2ND - SIDE EXT. WALL OF MAST BD BY WIG

SHEARWALL PROPERTIES:

WALL HEIGHT, H	<input type="text" value="8.0"/>	FT.	MAX WALL OPENING HT, H _c	<input type="text" value="4.0"/>	FT.	SHEARWALL ASSEMBLY	<input type="text" value="P1"/>
WALL LENGTH, L	<input type="text" value="10.8"/>	FT.	QUALIFYING WALL LENGTH, L	<input type="text" value="4.8"/>	FT.		

CAPACITY EVALUATION:

TOTAL SHEAR LOAD ON WALL	<input type="text" value="650"/>	LBS	<	ALLOWABLE SHEARWALL CAPACITY	<input type="text" value="1135"/>	LBS
--------------------------	----------------------------------	-----	---	------------------------------	-----------------------------------	-----

SHEARWALL ASSEMBLY SPECIFICATION

P1 - 1-SIDE 7/16" OSB
FASTENED W/ BD NAILS AT 6"D.C. PANEL EDGES & 12"D.C. PANEL FIELD - EDGES BLOCKED
ADEQUATE

OVERTURNING EVALUATION:

RESISTIVE DL	<input type="text" value="134"/>	PLF	OVERTURNING MOMENT	<input type="text" value="5.2"/>	K-FT	UPLIFT CONNECTOR DESIGN LOAD	<input type="text" value="0"/>	LBS
DL AT ENDS OF WALL	<input type="text" value="335"/>	LBS	RESISTIVE MOMENT	<input type="text" value="5.3"/>	K-FT	HOLDOWN CAPACITY	<input type="text" value="0"/>	LBS

HOLD-DOWN SPECIFICATION

NO HOLDOWN REQUIRED

SHEARWALL 206: 2ND - REAR EXT. WALL OF BD#2

SHEARWALL PROPERTIES:

WALL HEIGHT, H	<input type="text" value="8.0"/>	FT.	MAX WALL OPENING HT, H _c	<input type="text" value="0.0"/>	FT.	SHEARWALL ASSEMBLY	<input type="text" value="P3"/>
WALL LENGTH, L	<input type="text" value="17.0"/>	FT.	QUALIFYING WALL LENGTH, L	<input type="text" value="17.0"/>	FT.		

CAPACITY EVALUATION:

TOTAL SHEAR LOAD ON WALL	<input type="text" value="2225"/>	LBS	<	ALLOWABLE SHEARWALL CAPACITY	<input type="text" value="7667"/>	LBS
--------------------------	-----------------------------------	-----	---	------------------------------	-----------------------------------	-----

SHEARWALL ASSEMBLY SPECIFICATION

P3 - 1-SIDE 7/16" OSB
FASTENED W/ BD NAILS AT 3"D.C. PANEL EDGES & 12"D.C. PANEL FIELD - EDGES BLOCKED
ADEQUATE

OVERTURNING EVALUATION:

RESISTIVE DL	<input type="text" value="340"/>	PLF	OVERTURNING MOMENT	<input type="text" value="17.8"/>	K-FT	HOLD DOWN DESIGN LOAD	<input type="text" value="0"/>	LBS
DL AT ENDS OF WALL	<input type="text" value="0"/>	LBS	RESISTIVE MOMENT	<input type="text" value="23.1"/>	K-FT	HOLDOWN CAPACITY	<input type="text" value="0"/>	LBS

HOLD-DOWN SPECIFICATION

NO HOLDOWN REQUIRED



SHEARWALL DESIGN SUMMARY

SHEARWALL 207: 2ND - SIDE EXT. WALL OF BD#2 / BD#3

SHEARWALL PROPERTIES:

WALL HEIGHT, H	<input type="text" value="8.0"/>	FT.	MAX WALL OPENING HT, H _c	<input type="text" value="4.0"/>	FT.	SHEARWALL ASSEMBLY	<input type="text" value="P1"/>
WALL LENGTH, L	<input type="text" value="28.7"/>	FT.	QUALIFYING WALL LENGTH, L	<input type="text" value="12.7"/>	FT.		

CAPACITY EVALUATION:

TOTAL SHEAR LOAD ON WALL	<input type="text" value="1350"/>	LBS	<	ALLOWABLE SHEARWALL CAPACITY	<input type="text" value="3028"/>	LBS
--------------------------	-----------------------------------	-----	---	------------------------------	-----------------------------------	-----

SHEARWALL ASSEMBLY SPECIFICATION

P1 - 1-SIDE 7/16" OSB
FASTENED W/ BD NAILS AT 6"D.C. PANEL EDGES & 12"D.C. PANEL FIELD - EDGES BLOCKED
ADEQUATE

OVERTURNING EVALUATION:

RESISTIVE DL	<input type="text" value="134"/>	PLF	OVERTURNING MOMENT	<input type="text" value="10.8"/>	K-FT	UPLIFT CONNECTOR DESIGN LOAD	<input type="text" value="0"/>	LBS
DL AT ENDS OF WALL	<input type="text" value="200"/>	LBS	RESISTIVE MOMENT	<input type="text" value="28.6"/>	K-FT	HOLDOWN CAPACITY	<input type="text" value="0"/>	LBS

HOLD-DOWN SPECIFICATION

NO HOLDOWN REQUIRED

SHEARWALL 208: 2ND - FRONT EXT. WALL OF BD#3

SHEARWALL PROPERTIES:

WALL HEIGHT, H	<input type="text" value="8.0"/>	FT.	MAX WALL OPENING HT, H _c	<input type="text" value="1.7"/>	FT.	SHEARWALL ASSEMBLY	<input type="text" value="P1"/>
WALL LENGTH, L	<input type="text" value="21.0"/>	FT.	QUALIFYING WALL LENGTH, L	<input type="text" value="15.0"/>	FT.		

CAPACITY EVALUATION:

TOTAL SHEAR LOAD ON WALL	<input type="text" value="1250"/>	LBS	<	ALLOWABLE SHEARWALL CAPACITY	<input type="text" value="3585"/>	LBS
--------------------------	-----------------------------------	-----	---	------------------------------	-----------------------------------	-----

SHEARWALL ASSEMBLY SPECIFICATION

P1 - 1-SIDE 7/16" OSB
FASTENED W/ BD NAILS AT 6"D.C. PANEL EDGES & 12"D.C. PANEL FIELD - EDGES BLOCKED
ADEQUATE

OVERTURNING EVALUATION:

RESISTIVE DL	<input type="text" value="340"/>	PLF	OVERTURNING MOMENT	<input type="text" value="10.0"/>	K-FT	HOLD DOWN DESIGN LOAD	<input type="text" value="0"/>	LBS
DL AT ENDS OF WALL	<input type="text" value="200"/>	LBS	RESISTIVE MOMENT	<input type="text" value="37.3"/>	K-FT	HOLDOWN CAPACITY	<input type="text" value="0"/>	LBS

HOLD-DOWN SPECIFICATION

NO HOLDOWN REQUIRED



SHEARWALL DESIGN SUMMARY

SHEARWALL 209: 2ND - FRONT EXT. WALL OF MASTER WIC

SHEARWALL PROPERTIES:

WALL HEIGHT, H	<input type="text" value="8.0"/>	FT.	MAX WALL OPENING HT, H _c	<input type="text" value="4.0"/>	FT.	SHEARWALL ASSEMBLY	<input type="text" value="P1"/>
WALL LENGTH, L	<input type="text" value="13.0"/>	FT.	QUALIFYING WALL LENGTH, L	<input type="text" value="7.0"/>	FT.		

CAPACITY EVALUATION:

TOTAL SHEAR LOAD ON WALL	<input type="text" value="600"/>	LBS	<	ALLOWABLE SHEARWALL CAPACITY	<input type="text" value="1554"/>	LBS
--------------------------	----------------------------------	-----	---	------------------------------	-----------------------------------	-----

SHEARWALL ASSEMBLY SPECIFICATION

P1 - 1-SIDE 7/16" OSB
FASTENED W/ 8D NAILS AT 6"D.C. PANEL EDGES & 12"D.C. PANEL FIELD - EDGES BLOCKED
ADEQUATE

OVERTURNING EVALUATION:

RESISTIVE DL	<input type="text" value="260"/>	PLF	OVERTURNING MOMENT	<input type="text" value="4.8"/>	K-FT	UPLIFT CONNECTOR DESIGN LOAD	<input type="text" value="0"/>	LBS
DL AT ENDS OF WALL	<input type="text" value="535"/>	LBS	RESISTIVE MOMENT	<input type="text" value="13.6"/>	K-FT	HOLDOWN CAPACITY	<input type="text" value="0"/>	LBS

HOLD-DOWN SPECIFICATION

NO HOLDOWN REQUIRED

SHEARWALL 210: 2ND - SIDE EXT. WALL OF BD#3 WIC

SHEARWALL PROPERTIES:

WALL HEIGHT, H	<input type="text" value="8.0"/>	FT.	MAX WALL OPENING HT, H _c	<input type="text" value="0.0"/>	FT.	SHEARWALL ASSEMBLY	<input type="text" value="P1"/>
WALL LENGTH, L	<input type="text" value="6.0"/>	FT.	QUALIFYING WALL LENGTH, L	<input type="text" value="6.0"/>	FT.		

CAPACITY EVALUATION:

TOTAL SHEAR LOAD ON WALL	<input type="text" value="700"/>	LBS	<	ALLOWABLE SHEARWALL CAPACITY	<input type="text" value="1434"/>	LBS
--------------------------	----------------------------------	-----	---	------------------------------	-----------------------------------	-----

SHEARWALL ASSEMBLY SPECIFICATION

P1 - 1-SIDE 7/16" OSB
FASTENED W/ 8D NAILS AT 6"D.C. PANEL EDGES & 12"D.C. PANEL FIELD - EDGES BLOCKED
ADEQUATE

OVERTURNING EVALUATION:

RESISTIVE DL	<input type="text" value="134"/>	PLF	OVERTURNING MOMENT	<input type="text" value="5.6"/>	K-FT	HOLD DOWN DESIGN LOAD	<input type="text" value="618"/>	LBS
DL AT ENDS OF WALL	<input type="text" value="268"/>	LBS	RESISTIVE MOMENT	<input type="text" value="1.9"/>	K-FT	HOLDOWN CAPACITY	<input type="text" value="1705"/>	LBS

HOLD-DOWN SPECIFICATION

SIMPSON CS16 STRAP TIE (14" END LENGTH)
FASTENED W/ 26-8D NAILS



SHEARWALL DESIGN SUMMARY

SHEARWALL 211: 2ND - SIDE EXT. WALL OF MAST WIG BY ENTRY

SHEARWALL PROPERTIES:

WALL HEIGHT, H FT. MAX WALL OPENING HT, H_c FT.
WALL LENGTH, L FT. QUALIFYING WALL LENGTH, L FT. SHEARWALL ASSEMBLY

CAPACITY EVALUATION:

TOTAL SHEAR LOAD ON WALL LBS < ALLOWABLE SHEARWALL CAPACITY LBS

SHEARWALL ASSEMBLY SPECIFICATION

P1 - 1-SIDE 7/16" OSB
FASTENED W/ 8D NAILS AT 6"D.C. PANEL EDGES & 12"D.C. PANEL FIELD - EDGES BLOCKED
ADEQUATE

OVERTURNING EVALUATION:

RESISTIVE DL PLF OVERTURNING MOMENT K-FT UPLIFT CONNECTOR DESIGN LOAD LBS
DL AT ENDS OF WALL LBS RESISTIVE MOMENT K-FT HOLDOWN CAPACITY LBS

HOLD-DOWN SPECIFICATION

NO HOLDOWN REQUIRED

SHEARWALL XXX: - NOT USED

SHEARWALL PROPERTIES:

WALL HEIGHT, H FT. MAX WALL OPENING HT, H_c FT.
WALL LENGTH, L FT. QUALIFYING WALL LENGTH, L FT. SHEARWALL ASSEMBLY

CAPACITY EVALUATION:

TOTAL SHEAR LOAD ON WALL LBS **#####** ALLOWABLE SHEARWALL CAPACITY LBS

SHEARWALL ASSEMBLY SPECIFICATION

PO - 1-SIDE 7/16" OSB
FASTENED W/ 8D NAILS AT 6"D.C. PANEL EDGES & 12"D.C. PANEL FIELD - UNBLOCKED
#DIV/0!

OVERTURNING EVALUATION:

RESISTIVE DL PLF OVERTURNING MOMENT K-FT HOLD DOWN DESIGN LOAD LBS
DL AT ENDS OF WALL LBS RESISTIVE MOMENT K-FT HOLDOWN CAPACITY LBS

HOLD-DOWN SPECIFICATION

NO HOLDOWN REQUIRED



SHEARWALL DESIGN SUMMARY

SHEARWALL 101: 1ST - SIDE EXT. WALL OF GUEST ROOM/BATH #3

SHEARWALL PROPERTIES:

WALL HEIGHT, H	<input type="text" value="10.0"/>	FT.	MAX WALL OPENING HT, H _c	<input type="text" value="6.5"/>	FT.	SHEARWALL ASSEMBLY	<input type="text" value="P1"/>
WALL LENGTH, L	<input type="text" value="23.2"/>	FT.	QUALIFYING WALL LENGTH, L	<input type="text" value="18.2"/>	FT.		

CAPACITY EVALUATION:

TOTAL SHEAR LOAD ON WALL	<input type="text" value="1300"/>	LBS	<	ALLOWABLE SHEARWALL CAPACITY	<input type="text" value="1937"/>	LBS
--------------------------	-----------------------------------	-----	---	------------------------------	-----------------------------------	-----

SHEARWALL ASSEMBLY SPECIFICATION

P1 - 1-SIDE 7/16" OSB
FASTENED W/ 8D NAILS AT 6"D.C. PANEL EDGES & 12"D.C. PANEL FIELD - EDGES BLOCKED
ADEQUATE

OVERTURNING EVALUATION:

RESISTIVE DL	<input type="text" value="234"/>	PLF	OVERTURNING MOMENT	<input type="text" value="13.0"/>	K-FT	UPLIFT CONNECTOR DESIGN LOAD	<input type="text" value="0"/>	LBS
DL AT ENDS OF WALL	<input type="text" value="370"/>	LBS	RESISTIVE MOMENT	<input type="text" value="33.6"/>	K-FT	HOLDOWN CAPACITY	<input type="text" value="0"/>	LBS

HOLD-DOWN SPECIFICATION

NO HOLDOWN REQUIRED

SHEARWALL 102: 1ST - REAR EXT. WALL OF BATH #3

SHEARWALL PROPERTIES:

WALL HEIGHT, H	<input type="text" value="10.0"/>	FT.	MAX WALL OPENING HT, H _c	<input type="text" value="0.0"/>	FT.	SHEARWALL ASSEMBLY	<input type="text" value="P3"/>
WALL LENGTH, L	<input type="text" value="4.3"/>	FT.	QUALIFYING WALL LENGTH, L	<input type="text" value="4.3"/>	FT.		

CAPACITY EVALUATION:

TOTAL SHEAR LOAD ON WALL	<input type="text" value="1150"/>	LBS	<	ALLOWABLE SHEARWALL CAPACITY	<input type="text" value="1832"/>	LBS
--------------------------	-----------------------------------	-----	---	------------------------------	-----------------------------------	-----

SHEARWALL ASSEMBLY SPECIFICATION

P3 - 1-SIDE 7/16" OSB
FASTENED W/ 8D NAILS AT 3"D.C. PANEL EDGES & 12"D.C. PANEL FIELD - EDGES BLOCKED
ADEQUATE

OVERTURNING EVALUATION:

RESISTIVE DL	<input type="text" value="410"/>	PLF	OVERTURNING MOMENT	<input type="text" value="11.5"/>	K-FT	HOLD DOWN DESIGN LOAD	<input type="text" value="2178"/>	LBS
DL AT ENDS OF WALL	<input type="text" value="250"/>	LBS	RESISTIVE MOMENT	<input type="text" value="2.2"/>	K-FT	HOLDOWN CAPACITY	<input type="text" value="3105"/>	LBS

HOLD-DOWN SPECIFICATION

SIMPSON HTT4 HOLDOWN
FASTENED W/ 18-10D NAILS W/ 5/8" DIA. ALL-THREAD ROD



SHEARWALL DESIGN SUMMARY

SHEARWALL 103: 1ST - SIDE EXT. WALL OF LIVING ROOM

SHEARWALL PROPERTIES:

WALL HEIGHT, H	<input type="text" value="10.0"/>	FT.	MAX WALL OPENING HT, H _c	<input type="text" value="7.5"/>	FT.	SHEARWALL ASSEMBLY	<input type="text" value="P3"/>
WALL LENGTH, L	<input type="text" value="18.0"/>	FT.	QUALIFYING WALL LENGTH, L	<input type="text" value="15.0"/>	FT.		

CAPACITY EVALUATION:

TOTAL SHEAR LOAD ON WALL	<input type="text" value="2000"/>	LBS	<	ALLOWABLE SHEARWALL CAPACITY	<input type="text" value="2030"/>	LBS
--------------------------	-----------------------------------	-----	---	------------------------------	-----------------------------------	-----

SHEARWALL ASSEMBLY SPECIFICATION

P3 - 1-SIDE 7/16" OSB
FASTENED W/ 8D NAILS AT 3"D.C. PANEL EDGES & 12"D.C. PANEL FIELD - EDGES BLOCKED
ADEQUATE

OVERTURNING EVALUATION:

RESISTIVE DL	<input type="text" value="234"/>	PLF	OVERTURNING MOMENT	<input type="text" value="20.0"/>	K-FT	UPLIFT CONNECTOR DESIGN LOAD	<input type="text" value="0"/>	LBS
DL AT ENDS OF WALL	<input type="text" value="700"/>	LBS	RESISTIVE MOMENT	<input type="text" value="23.8"/>	K-FT	HOLDOWN CAPACITY	<input type="text" value="0"/>	LBS

HOLD-DOWN SPECIFICATION

NO HOLDOWN REQUIRED

SHEARWALL 104: 1ST - REAR EXT. WALL OF LIVING ROOM

SHEARWALL PROPERTIES:

WALL HEIGHT, H	<input type="text" value="10.0"/>	FT.	MAX WALL OPENING HT, H _c	<input type="text" value="7.5"/>	FT.	SHEARWALL ASSEMBLY	<input type="text" value="P1"/>
WALL LENGTH, L	<input type="text" value="24.5"/>	FT.	QUALIFYING WALL LENGTH, L	<input type="text" value="14.5"/>	FT.		

CAPACITY EVALUATION:

TOTAL SHEAR LOAD ON WALL	<input type="text" value="1200"/>	LBS	<	ALLOWABLE SHEARWALL CAPACITY	<input type="text" value="1464"/>	LBS
--------------------------	-----------------------------------	-----	---	------------------------------	-----------------------------------	-----

SHEARWALL ASSEMBLY SPECIFICATION

P1 - 1-SIDE 7/16" OSB
FASTENED W/ 8D NAILS AT 6"D.C. PANEL EDGES & 12"D.C. PANEL FIELD - EDGES BLOCKED
ADEQUATE

OVERTURNING EVALUATION:

RESISTIVE DL	<input type="text" value="365"/>	PLF	OVERTURNING MOMENT	<input type="text" value="12.0"/>	K-FT	HOLD DOWN DESIGN LOAD	<input type="text" value="0"/>	LBS
DL AT ENDS OF WALL	<input type="text" value="400"/>	LBS	RESISTIVE MOMENT	<input type="text" value="56.2"/>	K-FT	HOLDOWN CAPACITY	<input type="text" value="0"/>	LBS

HOLD-DOWN SPECIFICATION

NO HOLDOWN REQUIRED



SHEARWALL DESIGN SUMMARY

SHEARWALL 105: 1ST - SIDE EXT. WALL OF LIVING ROOM BY COV DECK

SHEARWALL PROPERTIES:

WALL HEIGHT, H	<input type="text" value="10.0"/>	FT.	MAX WALL OPENING HT, H _c	<input type="text" value="7.5"/>	FT.	SHEARWALL ASSEMBLY	<input type="text" value="P3"/>
WALL LENGTH, L	<input type="text" value="10.8"/>	FT.	QUALIFYING WALL LENGTH, L	<input type="text" value="4.8"/>	FT.		

CAPACITY EVALUATION:

TOTAL SHEAR LOAD ON WALL	<input type="text" value="800"/>	LBS	<	ALLOWABLE SHEARWALL CAPACITY	<input type="text" value="1212"/>	LBS
--------------------------	----------------------------------	-----	---	------------------------------	-----------------------------------	-----

SHEARWALL ASSEMBLY SPECIFICATION

P3 - 1-SIDE 7/16" OSB
FASTENED W/ 8D NAILS AT 3"D.C. PANEL EDGES & 12"D.C. PANEL FIELD - EDGES BLOCKED
ADEQUATE

OVERTURNING EVALUATION:

RESISTIVE DL	<input type="text" value="234"/>	PLF	OVERTURNING MOMENT	<input type="text" value="8.0"/>	K-FT	UPLIFT CONNECTOR DESIGN LOAD	<input type="text" value="0"/>	LBS
DL AT ENDS OF WALL	<input type="text" value="1700"/>	LBS	RESISTIVE MOMENT	<input type="text" value="15.0"/>	K-FT	HOLDOWN CAPACITY	<input type="text" value="0"/>	LBS

HOLD-DOWN SPECIFICATION

NO HOLDOWN REQUIRED

SHEARWALL 106: 1ST - REAR EXT. WALL OF DINING ROOM

SHEARWALL PROPERTIES:

WALL HEIGHT, H	<input type="text" value="10.0"/>	FT.	MAX WALL OPENING HT, H _c	<input type="text" value="0.0"/>	FT.	SHEARWALL ASSEMBLY	<input type="text" value="P3"/>
WALL LENGTH, L	<input type="text" value="2.8"/>	FT.	QUALIFYING WALL LENGTH, L	<input type="text" value="2.8"/>	FT.		

CAPACITY EVALUATION:

TOTAL SHEAR LOAD ON WALL	<input type="text" value="700"/>	LBS	<	ALLOWABLE SHEARWALL CAPACITY	<input type="text" value="1008"/>	LBS
--------------------------	----------------------------------	-----	---	------------------------------	-----------------------------------	-----

SHEARWALL ASSEMBLY SPECIFICATION

P3 - 1-SIDE 7/16" OSB
FASTENED W/ 8D NAILS AT 3"D.C. PANEL EDGES & 12"D.C. PANEL FIELD - EDGES BLOCKED
ADEQUATE

OVERTURNING EVALUATION:

RESISTIVE DL	<input type="text" value="575"/>	PLF	OVERTURNING MOMENT	<input type="text" value="7.0"/>	K-FT	HOLD DOWN DESIGN LOAD	<input type="text" value="1467"/>	LBS
DL AT ENDS OF WALL	<input type="text" value="1500"/>	LBS	RESISTIVE MOMENT	<input type="text" value="3.0"/>	K-FT	HOLDOWN CAPACITY	<input type="text" value="3105"/>	LBS

HOLD-DOWN SPECIFICATION

SIMPSON HTT4 HOLDOWN
FASTENED W/ 18-10D NAILS W/ 5/8" DIA. ALL-THREAD ROD



SHEARWALL DESIGN SUMMARY

SHEARWALL 107: 1ST - REAR EXT. WALL OF DINING ROOM

SHEARWALL PROPERTIES:

WALL HEIGHT, H	<input type="text" value="10.0"/>	FT.	MAX WALL OPENING HT, H _c	<input type="text" value="0.0"/>	FT.	SHEARWALL ASSEMBLY	<input type="text" value="P3"/>
WALL LENGTH, L	<input type="text" value="4.3"/>	FT.	QUALIFYING WALL LENGTH, L	<input type="text" value="4.3"/>	FT.		

CAPACITY EVALUATION:

TOTAL SHEAR LOAD ON WALL	<input type="text" value="1050"/>	LBS	<	ALLOWABLE SHEARWALL CAPACITY	<input type="text" value="1832"/>	LBS
--------------------------	-----------------------------------	-----	---	------------------------------	-----------------------------------	-----

SHEARWALL ASSEMBLY SPECIFICATION

P3 - 1-SIDE 7/16" OSB
FASTENED W/ 8D NAILS AT 3"D.C. PANEL EDGES & 12"D.C. PANEL FIELD - EDGES BLOCKED
ADEQUATE

OVERTURNING EVALUATION:

RESISTIVE DL	<input type="text" value="290"/>	PLF	OVERTURNING MOMENT	<input type="text" value="10.5"/>	K-FT	UPLIFT CONNECTOR DESIGN LOAD	<input type="text" value="1771"/>	LBS
DL AT ENDS OF WALL	<input type="text" value="870"/>	LBS	RESISTIVE MOMENT	<input type="text" value="3.0"/>	K-FT	HOLD-DOWN CAPACITY	<input type="text" value="3105"/>	LBS

HOLD-DOWN SPECIFICATION

SIMPSON HTT4 HOLD-DOWN
FASTENED W/ 18-10D NAILS W/ 5/8" DIA. ALL-THREAD ROD

SHEARWALL 108: 1ST - SIDE EXT. WALL OF KITCHEN

SHEARWALL PROPERTIES:

WALL HEIGHT, H	<input type="text" value="10.0"/>	FT.	MAX WALL OPENING HT, H _c	<input type="text" value="7.0"/>	FT.	SHEARWALL ASSEMBLY	<input type="text" value="P3"/>
WALL LENGTH, L	<input type="text" value="16.0"/>	FT.	QUALIFYING WALL LENGTH, L	<input type="text" value="11.0"/>	FT.		

CAPACITY EVALUATION:

TOTAL SHEAR LOAD ON WALL	<input type="text" value="1147"/>	LBS	<	ALLOWABLE SHEARWALL CAPACITY	<input type="text" value="2165"/>	LBS
--------------------------	-----------------------------------	-----	---	------------------------------	-----------------------------------	-----

SHEARWALL ASSEMBLY SPECIFICATION

P3 - 1-SIDE 7/16" OSB
FASTENED W/ 8D NAILS AT 3"D.C. PANEL EDGES & 12"D.C. PANEL FIELD - EDGES BLOCKED
ADEQUATE

OVERTURNING EVALUATION:

RESISTIVE DL	<input type="text" value="234"/>	PLF	OVERTURNING MOMENT	<input type="text" value="11.5"/>	K-FT	HOLD-DOWN DESIGN LOAD	<input type="text" value="0"/>	LBS
DL AT ENDS OF WALL	<input type="text" value="400"/>	LBS	RESISTIVE MOMENT	<input type="text" value="17.1"/>	K-FT	HOLD-DOWN CAPACITY	<input type="text" value="0"/>	LBS

HOLD-DOWN SPECIFICATION

NO HOLD-DOWN REQUIRED



SHEARWALL DESIGN SUMMARY

SHEARWALL 109: 1ST - SIDE EXT. WALL OF GARAGE

SHEARWALL PROPERTIES:

WALL HEIGHT, H	<input type="text" value="11.0"/>	FT.	MAX WALL OPENING HT, H _c	<input type="text" value="7.0"/>	FT.	SHEARWALL ASSEMBLY	<input type="text" value="P1"/>
WALL LENGTH, L	<input type="text" value="27.3"/>	FT.	QUALIFYING WALL LENGTH, L	<input type="text" value="22.3"/>	FT.		

CAPACITY EVALUATION:

TOTAL SHEAR LOAD ON WALL	<input type="text" value="603"/>	LBS	<	ALLOWABLE SHEARWALL CAPACITY	<input type="text" value="2368"/>	LBS
--------------------------	----------------------------------	-----	---	------------------------------	-----------------------------------	-----

SHEARWALL ASSEMBLY SPECIFICATION

P1 - 1-SIDE 7/16" OSB
FASTENED W/ 8D NAILS AT 6"D.C. PANEL EDGES & 12"D.C. PANEL FIELD - EDGES BLOCKED
ADEQUATE

OVERTURNING EVALUATION:

RESISTIVE DL	<input type="text" value="275"/>	PLF	OVERTURNING MOMENT	<input type="text" value="6.6"/>	K-FT	UPLIFT CONNECTOR DESIGN LOAD	<input type="text" value="0"/>	LBS
DL AT ENDS OF WALL	<input type="text" value="400"/>	LBS	RESISTIVE MOMENT	<input type="text" value="53.2"/>	K-FT	HOLDOWN CAPACITY	<input type="text" value="0"/>	LBS

HOLD-DOWN SPECIFICATION

NO HOLDOWN REQUIRED

SHEARWALL 110: 1ST - FRONT EXT. WALL OF GARAGE

SHEARWALL PROPERTIES:

WALL HEIGHT, H	<input type="text" value="11.0"/>	FT.	MAX WALL OPENING HT, H _c	<input type="text" value="8.0"/>	FT.	SHEARWALL ASSEMBLY	<input type="text" value="P1"/>
WALL LENGTH, L	<input type="text" value="21.0"/>	FT.	QUALIFYING WALL LENGTH, L	<input type="text" value="18.0"/>	FT.		

CAPACITY EVALUATION:

TOTAL SHEAR LOAD ON WALL	<input type="text" value="1300"/>	LBS	<	ALLOWABLE SHEARWALL CAPACITY	<input type="text" value="1369"/>	LBS
--------------------------	-----------------------------------	-----	---	------------------------------	-----------------------------------	-----

SHEARWALL ASSEMBLY SPECIFICATION

P1 - 1-SIDE 7/16" OSB
FASTENED W/ 8D NAILS AT 6"D.C. PANEL EDGES & 12"D.C. PANEL FIELD - EDGES BLOCKED
ADEQUATE

OVERTURNING EVALUATION:

RESISTIVE DL	<input type="text" value="100"/>	PLF	OVERTURNING MOMENT	<input type="text" value="14.3"/>	K-FT	HOLD DOWN DESIGN LOAD	<input type="text" value="0"/>	LBS
DL AT ENDS OF WALL	<input type="text" value="400"/>	LBS	RESISTIVE MOMENT	<input type="text" value="14.3"/>	K-FT	HOLDOWN CAPACITY	<input type="text" value="0"/>	LBS

HOLD-DOWN SPECIFICATION

NO HOLDOWN REQUIRED



SHEARWALL DESIGN SUMMARY

SHEARWALL 111: 1ST - FRONT EXT. WALL OF GUEST ROOM

SHEARWALL PROPERTIES:

WALL HEIGHT, H	<input type="text" value="10.0"/>	FT.	MAX WALL OPENING HT, H _c	<input type="text" value="7.5"/>	FT.	SHEARWALL ASSEMBLY	<input type="text" value="P3"/>
WALL LENGTH, L	<input type="text" value="13.0"/>	FT.	QUALIFYING WALL LENGTH, L	<input type="text" value="7.0"/>	FT.		

CAPACITY EVALUATION:

TOTAL SHEAR LOAD ON WALL	<input type="text" value="1250"/>	LBS	<	ALLOWABLE SHEARWALL CAPACITY	<input type="text" value="1466"/>	LBS
--------------------------	-----------------------------------	-----	---	------------------------------	-----------------------------------	-----

SHEARWALL ASSEMBLY SPECIFICATION

P3 - 1-SIDE 7/16" OSB
FASTENED W/ 8D NAILS AT 3"D.C. PANEL EDGES & 12"D.C. PANEL FIELD - EDGES BLOCKED
ADEQUATE

OVERTURNING EVALUATION:

RESISTIVE DL	<input type="text" value="425"/>	PLF	OVERTURNING MOMENT	<input type="text" value="12.5"/>	K-FT	UPLIFT CONNECTOR DESIGN LOAD	<input type="text" value="0"/>	LBS
DL AT ENDS OF WALL	<input type="text" value="935"/>	LBS	RESISTIVE MOMENT	<input type="text" value="22.6"/>	K-FT	HOLDOWN CAPACITY	<input type="text" value="0"/>	LBS

HOLD-DOWN SPECIFICATION

NO HOLDOWN REQUIRED

SHEARWALL 112: 1ST - SIDE EXT. WALL OF GUEST RM BY ENTRY

SHEARWALL PROPERTIES:

WALL HEIGHT, H	<input type="text" value="10.0"/>	FT.	MAX WALL OPENING HT, H _c	<input type="text" value="0.0"/>	FT.	SHEARWALL ASSEMBLY	<input type="text" value="P1"/>
WALL LENGTH, L	<input type="text" value="13.2"/>	FT.	QUALIFYING WALL LENGTH, L	<input type="text" value="13.2"/>	FT.		

CAPACITY EVALUATION:

TOTAL SHEAR LOAD ON WALL	<input type="text" value="1000"/>	LBS	<	ALLOWABLE SHEARWALL CAPACITY	<input type="text" value="3145"/>	LBS
--------------------------	-----------------------------------	-----	---	------------------------------	-----------------------------------	-----

SHEARWALL ASSEMBLY SPECIFICATION

P1 - 1-SIDE 7/16" OSB
FASTENED W/ 8D NAILS AT 6"D.C. PANEL EDGES & 12"D.C. PANEL FIELD - EDGES BLOCKED
ADEQUATE

OVERTURNING EVALUATION:

RESISTIVE DL	<input type="text" value="234"/>	PLF	OVERTURNING MOMENT	<input type="text" value="10.0"/>	K-FT	HOLD DOWN DESIGN LOAD	<input type="text" value="0"/>	LBS
DL AT ENDS OF WALL	<input type="text" value="834"/>	LBS	RESISTIVE MOMENT	<input type="text" value="14.7"/>	K-FT	HOLDOWN CAPACITY	<input type="text" value="0"/>	LBS

HOLD-DOWN SPECIFICATION

NO HOLDOWN REQUIRED



SHEARWALL DESIGN SUMMARY

SHEARWALL 113: 1ST - REAR INT. WALL OF GARAGE

SHEARWALL PROPERTIES:

WALL HEIGHT, H FT. MAX WALL OPENING HT, H_c FT.
WALL LENGTH, L FT. QUALIFYING WALL LENGTH, L FT. SHEARWALL ASSEMBLY

CAPACITY EVALUATION:

TOTAL SHEAR LOAD ON WALL LBS < ALLOWABLE SHEARWALL CAPACITY LBS

SHEARWALL ASSEMBLY SPECIFICATION

P3 - 1-SIDE 7/16" OSB
FASTENED W/ 8D NAILS AT 3"D.C. PANEL EDGES & 12"D.C. PANEL FIELD - EDGES BLOCKED
ADEQUATE

OVERTURNING EVALUATION:

RESISTIVE DL PLF OVERTURNING MOMENT K-FT UPLIFT CONNECTOR DESIGN LOAD LBS
DL AT ENDS OF WALL LBS RESISTIVE MOMENT K-FT HOLDDOWN CAPACITY LBS

HOLD-DOWN SPECIFICATION

SIMPSON HTT4 HOLDDOWN
FASTENED W/ 18-10D NAILS W/ 5/8" DIA. ALL-THREAD ROD

SHEARWALL XXX: - NOT USED

SHEARWALL PROPERTIES:

WALL HEIGHT, H FT. MAX WALL OPENING HT, H_c FT.
WALL LENGTH, L FT. QUALIFYING WALL LENGTH, L FT. SHEARWALL ASSEMBLY

CAPACITY EVALUATION:

TOTAL SHEAR LOAD ON WALL LBS **#####** ALLOWABLE SHEARWALL CAPACITY LBS

SHEARWALL ASSEMBLY SPECIFICATION

P1 - 1-SIDE 7/16" OSB
FASTENED W/ 8D NAILS AT 6"D.C. PANEL EDGES & 12"D.C. PANEL FIELD - EDGES BLOCKED
#DIV/0!

OVERTURNING EVALUATION:

RESISTIVE DL PLF OVERTURNING MOMENT K-FT HOLD DOWN DESIGN LOAD LBS
DL AT ENDS OF WALL LBS RESISTIVE MOMENT K-FT HOLDDOWN CAPACITY LBS

HOLD-DOWN SPECIFICATION

NO HOLDDOWN REQUIRED



SHEARWALL DESIGN SUMMARY

SHEARWALL 1: BASEMENT - SIDE EXT. KNEEWALL OF REC RM WET BAR

SHEARWALL PROPERTIES:

WALL HEIGHT, H	<input type="text" value="2.8"/>	FT.	MAX WALL OPENING HT, H _c	<input type="text" value="0.0"/>	FT.	SHEARWALL ASSEMBLY	<input type="text" value="P3"/>
WALL LENGTH, L	<input type="text" value="6.8"/>	FT.	QUALIFYING WALL LENGTH, L	<input type="text" value="6.8"/>	FT.		

CAPACITY EVALUATION:

TOTAL SHEAR LOAD ON WALL	<input type="text" value="2600"/>	LBS	<	ALLOWABLE SHEARWALL CAPACITY	<input type="text" value="3044"/>	LBS
--------------------------	-----------------------------------	-----	---	------------------------------	-----------------------------------	-----

SHEARWALL ASSEMBLY SPECIFICATION

P3 - 1-SIDE 7/16" OSB
FASTENED W/ 8D NAILS AT 3"D.C. PANEL EDGES & 12"D.C. PANEL FIELD - EDGES BLOCKED
ADEQUATE

OVERTURNING EVALUATION:

RESISTIVE DL	<input type="text" value="334"/>	PLF	OVERTURNING MOMENT	<input type="text" value="7.2"/>	K-FT	UPLIFT CONNECTOR DESIGN LOAD	<input type="text" value="340"/>	LBS
DL AT ENDS OF WALL	<input type="text" value="400"/>	LBS	RESISTIVE MOMENT	<input type="text" value="4.9"/>	K-FT	HOLDOWN CAPACITY	<input type="text" value="3105"/>	LBS

HOLD-DOWN SPECIFICATION

SIMPSON HTT4 HOLDOWN
FASTENED W/ 18-10D NAILS W/ 5/8" DIA. ALL-THREAD ROD

SHEARWALL 2: BASEMENT - REAR EXT. WALL OF REC ROOM

SHEARWALL PROPERTIES:

WALL HEIGHT, H	<input type="text" value="8.0"/>	FT.	MAX WALL OPENING HT, H _c	<input type="text" value="1.5"/>	FT.	SHEARWALL ASSEMBLY	<input type="text" value="P1"/>
WALL LENGTH, L	<input type="text" value="17.0"/>	FT.	QUALIFYING WALL LENGTH, L	<input type="text" value="12.0"/>	FT.		

CAPACITY EVALUATION:

TOTAL SHEAR LOAD ON WALL	<input type="text" value="1650"/>	LBS	<	ALLOWABLE SHEARWALL CAPACITY	<input type="text" value="2868"/>	LBS
--------------------------	-----------------------------------	-----	---	------------------------------	-----------------------------------	-----

SHEARWALL ASSEMBLY SPECIFICATION

P1 - 1-SIDE 7/16" OSB
FASTENED W/ 8D NAILS AT 6"D.C. PANEL EDGES & 12"D.C. PANEL FIELD - EDGES BLOCKED
ADEQUATE

OVERTURNING EVALUATION:

RESISTIVE DL	<input type="text" value="520"/>	PLF	OVERTURNING MOMENT	<input type="text" value="13.2"/>	K-FT	HOLD DOWN DESIGN LOAD	<input type="text" value="0"/>	LBS
DL AT ENDS OF WALL	<input type="text" value="800"/>	LBS	RESISTIVE MOMENT	<input type="text" value="41.8"/>	K-FT	HOLDOWN CAPACITY	<input type="text" value="0"/>	LBS

HOLD-DOWN SPECIFICATION

NO HOLDOWN REQUIRED



SHEARWALL DESIGN SUMMARY

SHEARWALL 3: BASEMENT - SIDE EXT. WALL OF REC ROOM

SHEARWALL PROPERTIES:

WALL HEIGHT, H	<input type="text" value="8.0"/>	FT.	MAX WALL OPENING HT, H _c	<input type="text" value="6.7"/>	FT.	SHEARWALL ASSEMBLY	<input type="text" value="P3"/>
WALL LENGTH, L	<input type="text" value="10.8"/>	FT.	QUALIFYING WALL LENGTH, L	<input type="text" value="4.8"/>	FT.		

CAPACITY EVALUATION:

TOTAL SHEAR LOAD ON WALL	<input type="text" value="800"/>	LBS	<	ALLOWABLE SHEARWALL CAPACITY	<input type="text" value="806"/>	LBS
--------------------------	----------------------------------	-----	---	------------------------------	----------------------------------	-----

SHEARWALL ASSEMBLY SPECIFICATION

P3 - 1-SIDE 7/16" OSB
FASTENED W/ 8D NAILS AT 3"D.C. PANEL EDGES & 12"D.C. PANEL FIELD - EDGES BLOCKED
ADEQUATE

OVERTURNING EVALUATION:

RESISTIVE DL	<input type="text" value="334"/>	PLF	OVERTURNING MOMENT	<input type="text" value="6.4"/>	K-FT	UPLIFT CONNECTOR DESIGN LOAD	<input type="text" value="0"/>	LBS
DL AT ENDS OF WALL	<input type="text" value="2000"/>	LBS	RESISTIVE MOMENT	<input type="text" value="19.2"/>	K-FT	HOLDOWN CAPACITY	<input type="text" value="0"/>	LBS

HOLD-DOWN SPECIFICATION

NO HOLDOWN REQUIRED

SHEARWALL 4: BASEMENT - REAR EXT. WALL OF CRAWLSPACE

SHEARWALL PROPERTIES:

WALL HEIGHT, H	<input type="text" value="8.0"/>	FT.	MAX WALL OPENING HT, H _c	<input type="text" value="0.0"/>	FT.	SHEARWALL ASSEMBLY	<input type="text" value="P1"/>
WALL LENGTH, L	<input type="text" value="15.0"/>	FT.	QUALIFYING WALL LENGTH, L	<input type="text" value="15.0"/>	FT.		

CAPACITY EVALUATION:

TOTAL SHEAR LOAD ON WALL	<input type="text" value="2300"/>	LBS	<	ALLOWABLE SHEARWALL CAPACITY	<input type="text" value="3585"/>	LBS
--------------------------	-----------------------------------	-----	---	------------------------------	-----------------------------------	-----

SHEARWALL ASSEMBLY SPECIFICATION

P1 - 1-SIDE 7/16" OSB
FASTENED W/ 8D NAILS AT 6"D.C. PANEL EDGES & 12"D.C. PANEL FIELD - EDGES BLOCKED
ADEQUATE

OVERTURNING EVALUATION:

RESISTIVE DL	<input type="text" value="505"/>	PLF	OVERTURNING MOMENT	<input type="text" value="18.4"/>	K-FT	HOLD DOWN DESIGN LOAD	<input type="text" value="0"/>	LBS
DL AT ENDS OF WALL	<input type="text" value="1000"/>	LBS	RESISTIVE MOMENT	<input type="text" value="33.8"/>	K-FT	HOLDOWN CAPACITY	<input type="text" value="0"/>	LBS

HOLD-DOWN SPECIFICATION

NO HOLDOWN REQUIRED



SHEARWALL DESIGN SUMMARY

SHEARWALL 5: BASEMENT - SIDE EXT. WALL OF CRAWLSPACE

SHEARWALL PROPERTIES:

WALL HEIGHT, H	<input type="text" value="5.3"/>	FT.	MAX WALL OPENING HT, H _c	<input type="text" value="0.0"/>	FT.	SHEARWALL ASSEMBLY	<input type="text" value="P1"/>
WALL LENGTH, L	<input type="text" value="25.5"/>	FT.	QUALIFYING WALL LENGTH, L	<input type="text" value="25.5"/>	FT.		

CAPACITY EVALUATION:

TOTAL SHEAR LOAD ON WALL	<input type="text" value="1450"/>	LBS	<	ALLOWABLE SHEARWALL CAPACITY	<input type="text" value="6095"/>	LBS
--------------------------	-----------------------------------	-----	---	------------------------------	-----------------------------------	-----

SHEARWALL ASSEMBLY SPECIFICATION

P1 - 1-SIDE 7/16" OSB
FASTENED W/ 8D NAILS AT 6"D.C. PANEL EDGES & 12"D.C. PANEL FIELD - EDGES BLOCKED
ADEQUATE

OVERTURNING EVALUATION:

RESISTIVE DL	<input type="text" value="334"/>	PLF	OVERTURNING MOMENT	<input type="text" value="7.6"/>	K-FT	UPLIFT CONNECTOR DESIGN LOAD	<input type="text" value="0"/>	LBS
DL AT ENDS OF WALL	<input type="text" value="800"/>	LBS	RESISTIVE MOMENT	<input type="text" value="60.7"/>	K-FT	HOLDOWN CAPACITY	<input type="text" value="0"/>	LBS

HOLD-DOWN SPECIFICATION

NO HOLDOWN REQUIRED

SHEARWALL 6: BASEMENT - KNEEWALL AT CRAWLSPACE BY REC RM

SHEARWALL PROPERTIES:

WALL HEIGHT, H	<input type="text" value="5.3"/>	FT.	MAX WALL OPENING HT, H _c	<input type="text" value="0.0"/>	FT.	SHEARWALL ASSEMBLY	<input type="text" value="P0"/>
WALL LENGTH, L	<input type="text" value="12.0"/>	FT.	QUALIFYING WALL LENGTH, L	<input type="text" value="12.0"/>	FT.		

CAPACITY EVALUATION:

TOTAL SHEAR LOAD ON WALL	<input type="text" value="400"/>	LBS	<	ALLOWABLE SHEARWALL CAPACITY	<input type="text" value="1728"/>	LBS
--------------------------	----------------------------------	-----	---	------------------------------	-----------------------------------	-----

SHEARWALL ASSEMBLY SPECIFICATION

P0 - 1-SIDE 7/16" OSB
FASTENED W/ 8D NAILS AT 6"D.C. PANEL EDGES & 12"D.C. PANEL FIELD - UNBLOCKED
ADEQUATE

OVERTURNING EVALUATION:

RESISTIVE DL	<input type="text" value="100"/>	PLF	OVERTURNING MOMENT	<input type="text" value="2.1"/>	K-FT	HOLD DOWN DESIGN LOAD	<input type="text" value="0"/>	LBS
DL AT ENDS OF WALL	<input type="text" value="150"/>	LBS	RESISTIVE MOMENT	<input type="text" value="4.2"/>	K-FT	HOLDOWN CAPACITY	<input type="text" value="0"/>	LBS

HOLD-DOWN SPECIFICATION

NO HOLDOWN REQUIRED



SHEARWALL DESIGN SUMMARY

SHEARWALL 7: BASEMENT - KNEEWALL AT CRAWLSPACE BY STARIS

SHEARWALL PROPERTIES:

WALL HEIGHT, H FT. MAX WALL OPENING HT, H_c FT.
WALL LENGTH, L FT. QUALIFYING WALL LENGTH, L FT. SHEARWALL ASSEMBLY

CAPACITY EVALUATION:

TOTAL SHEAR LOAD ON WALL LBS < ALLOWABLE SHEARWALL CAPACITY LBS

SHEARWALL ASSEMBLY SPECIFICATION

PO - 1-SIDE 7/16" OSB
FASTENED W/ 8D NAILS AT 6"O.C. PANEL EDGES & 12"O.C. PANEL FIELD - UNBLOCKED
ADEQUATE

OVERTURNING EVALUATION:

RESISTIVE DL PLF OVERTURNING MOMENT K-FT UPLIFT CONNECTOR DESIGN LOAD LBS
DL AT ENDS OF WALL LBS RESISTIVE MOMENT K-FT HOLDDOWN CAPACITY LBS

HOLD-DOWN SPECIFICATION

NO HOLDOWN REQUIRED

SHEARWALL XXX: - NOT USED

SHEARWALL PROPERTIES:

WALL HEIGHT, H FT. MAX WALL OPENING HT, H_c FT.
WALL LENGTH, L FT. QUALIFYING WALL LENGTH, L FT. SHEARWALL ASSEMBLY

CAPACITY EVALUATION:

TOTAL SHEAR LOAD ON WALL LBS ##### ALLOWABLE SHEARWALL CAPACITY LBS

SHEARWALL ASSEMBLY SPECIFICATION

PO - 1-SIDE 7/16" OSB
FASTENED W/ 8D NAILS AT 6"O.C. PANEL EDGES & 12"O.C. PANEL FIELD - UNBLOCKED
#DIV/0!

OVERTURNING EVALUATION:

RESISTIVE DL PLF OVERTURNING MOMENT K-FT HOLD DOWN DESIGN LOAD LBS
DL AT ENDS OF WALL LBS RESISTIVE MOMENT K-FT HOLDDOWN CAPACITY LBS

HOLD-DOWN SPECIFICATION

NO HOLDOWN REQUIRED